

SM2A-03-BLOCK II-(1)
APOLLO OPERATIONS HANDBOOK

SYSTEMS DATA

SECTION 2

SUBSECTION 2.4

SERVICE PROPULSION SYSTEM (SPS)
(CSM 106 and Subs)

2.4.1 FUNCTIONAL DESCRIPTION.

SPS

The service propulsion subsystem provides the impulse for all X-axis velocity changes (ΔV s) throughout a mission and the SPS abort capability after the launch escape tower is jettisoned. The SPS consists of a helium pressurization system, a propellant feed system, a propellant gauging and utilization system, and a rocket engine. The oxidizer is inhibited nitrogen tetroxide and the fuel is a blended hydrazine (approximately 50 percent unsymmetrical dimethyl hydrazine and 50 percent anhydrous hydrazine). The pressurizing gas is helium. The system incorporates displays and sensing devices to permit earth-based stations and the crew to monitor its operation. (See figures 2.4-1 and 2.4-2.)

The helium pressure is directed to the helium pressurizing valves which isolate the helium during nonthrusting periods, or allow the helium to pressurize the fuel and oxidizer tanks during thrusting periods. The helium pressure is reduced at the pressure regulators to a desired working pressure. The regulated helium pressure is directed through check valves that permit helium flow in the downstream direction when the pressurizing valves are open, and prevent a reverse flow of propellants during nonthrusting periods. The heat exchangers transfer heat from the propellants to the helium gas to reduce any pressure excursions that may result from a temperature differential between the helium gas and propellants in the tanks. The relief valves maintain the structural integrity of the propellant tank systems if an excessive pressure rise occurs.

The total propellant supply is contained within four similar tanks; an oxidizer storage tank, oxidizer sump tank, fuel storage tank, and fuel sump tank (figures 2.4-1, 2.4-2, and 2.4-3). The storage and sump tanks for each propellant system are connected in series by a single transfer line. The regulated helium enters the fuel and oxidizer storage tank, pressurizing the storage tank propellants, and forces the propellant to an outlet in the storage tank which is directed through a transfer line into the respective sump tank standpipe pressurizing the propellants in the sump tank. The propellant in the sump tank is directed to the exit end into a propellant retention reservoir. Sufficient propellants are retained in the

SERVICE PROPULSION SYSTEM

SYSTEMS DATA

retention reservoir and at the tank outlets to permit engine restart capability in a 0-g condition when the SPS propellant quantity remaining is greater than 22,300 pounds (56.4%) without conducting an SM RCS ullage maneuver prior to an SPS engine thrusting period. An ullage maneuver is mandatory prior to any SPS thrusting period when the SPS propellant quantity remaining is at or less than 22,300 pounds (56.4%). An ullage maneuver is also mandatory prior to any SPS thrusting period following all docked LM DPS burns even though the SPS propellant quantity is at or greater than 22,300 pounds (56.4%). The propellants exit from the respective sump tanks into a single line to the heat exchanger.

A propellant utilization valve is installed in the oxidizer line. The propellant utilization valve is powered only during SPS thrusting periods. The propellant utilization valve aids in achieving simultaneous propellant depletion. The propellant supply is connected from the sump tanks to the engine interface flange.

The propellants flow from the propellant sump tank, through their respective plumbing, to the main propellant orifices and filters, to the bipropellant valve. The bipropellant valve assembly contains pneumatically controlled main propellant valves that distribute the propellants to the engine injector.

The thrust chamber consists of an engine injector, combustion chamber, and exhaust nozzle extension. The engine injector distributes the propellants through orifices in the injector face where the fuel and oxidizer impinge, atomize, and ignite. The combustion chamber is ablatively cooled. The exhaust nozzle extension is radiation cooled.

The engine assembly is mounted to the structure of the SM. It is gimballed to permit thrust vector alignment through the center of mass prior to thrust initiation and thrust vector control during a thrusting period.

Propellant quantity is measured by two separate sensing systems: primary and auxiliary. The sensing systems are powered only during thrust-on periods because of the capacitance and point sensor measuring techniques. The capacitance and point sensor linearity would not provide accurate indications during the 0-g nonSPS thrusting periods.

The control of the subsystem is automatic with provisions for manual backup.

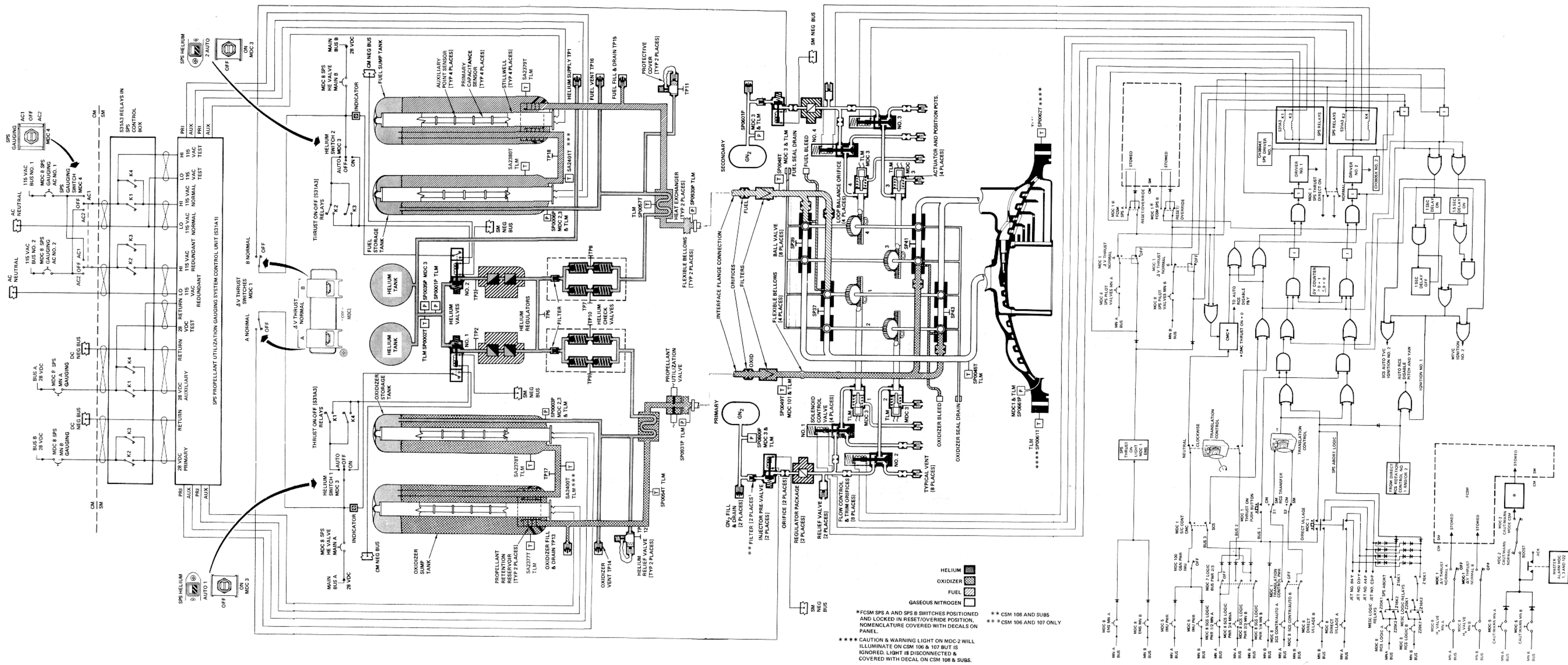

Figure 2.4-1. SPS Functional Flow Diagram (CSM 106 Thru CSM 111)

SERVICE PROPELLANT SYSTEM

SPS

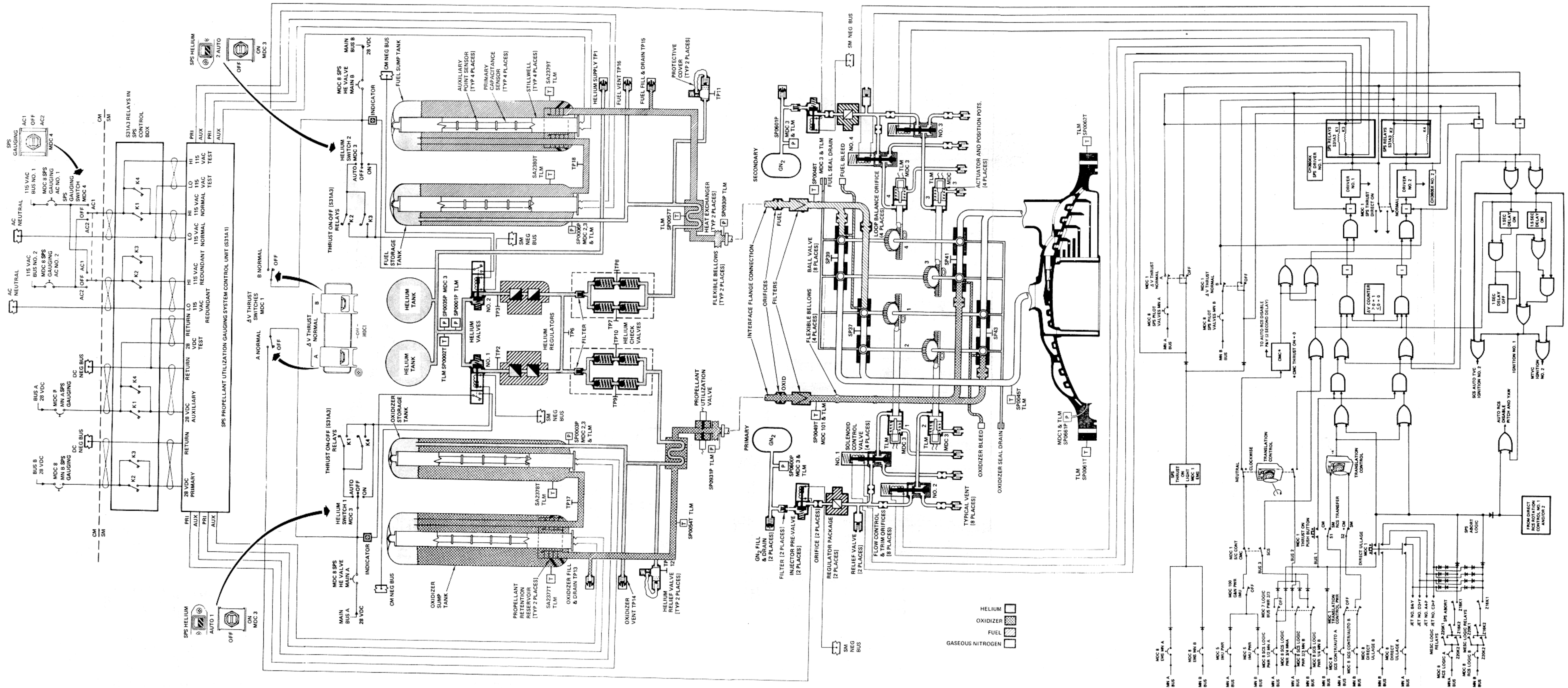
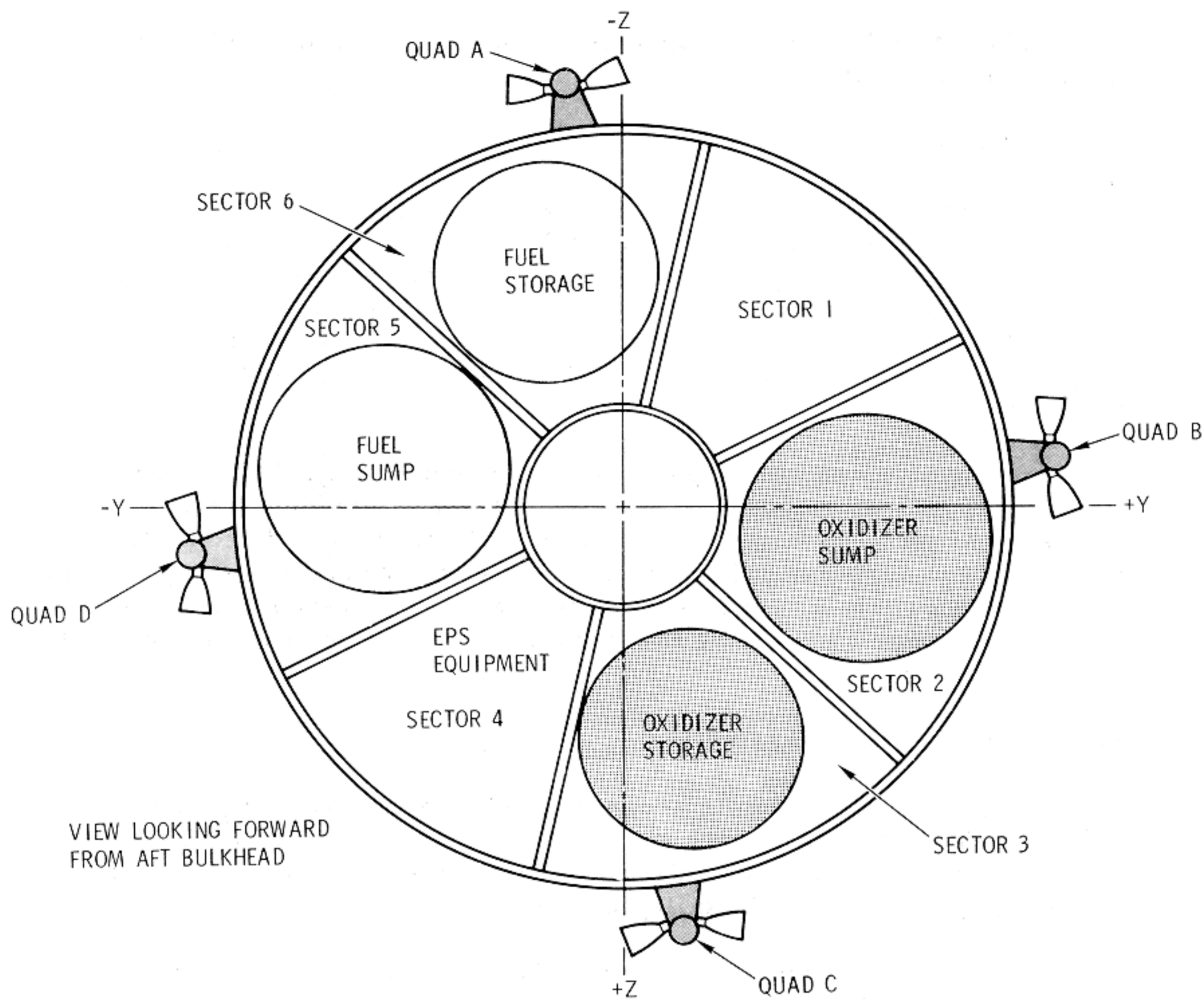

Figure 2.4-2. SPS Functional Flow Diagram (CSM 112 and Subs)

SERVICE PROPULSION SYSTEM

SYSTEMS DATA



SPS

P-5038

Figure 2.4-3. Service Module Sectors

2.4.2 MAJOR COMPONENT/SUBSYSTEM DESCRIPTION.

2.4.2.1 Pressurization Subsystem.

The pressurization subsystem consists of two helium tanks, two helium pressurizing valves, two dual pressure regulator assemblies, two dual check valve assemblies, two pressure relief valves, and two heat exchangers. The critical components are redundant to increase reliability.

SERVICE PROPULSION SYSTEM

SYSTEMS DATA

2.4.2.1.1 Helium Tanks.

The two helium supply spherical pressure vessels are located in the center section of the SM.

2.4.2.1.2 Helium Pressurizing Valves.

The helium valves are continuous-duty solenoid-operated. The valves are energized open and spring-loaded closed. The SPS He VLV switches on MDC-3 permit automatic or manual control of the valves. With the switches in the AUTO position, the valves are automatically controlled by a thrust ON-OFF signal. The valves are controlled manually by placing the switches to the ON (valve open) and OFF (valve closed) positions.

Each valve contains a position switch which controls a position (talk-back) indicator above each switch. When the valves are closed, the position switch is open and the indicator is barber pole (diagonal lines), the indication during nonSPS thrusting periods. When the valves are open, the position switch is closed and the indicator is powered to gray (same color as the panel) indicating the valve is open, the indication during SPS thrusting periods.

2.4.2.1.3 Pressure Regulator Assemblies.

Pressure regulation is accomplished by a pressure-regulating assembly downstream of each helium pressurizing valve. Each assembly contains a primary and secondary regulator in series, and a pressure surge damper and filter installed on the inlet to each regulating unit.

The primary regulator is normally the controlling regulator. The secondary regulator is normally open during a dynamic flow condition. The secondary regulator will not become the controlling regulator until the primary regulator allows a higher pressure than normal and allows the secondary regulator to function. All regulator pressures are in reference to a bellows assembly that is vented to ambient.

Only one of the parallel regulator assemblies regulates helium pressure under dynamic conditions. The downstream pressure causes the second assembly to lock up (close). When the regulated pressure decreases below the lockup pressure of the nonoperating assembly, that assembly becomes operational.

SYSTEMS DATA

2.4.2.1.4 Check Valve Assemblies.

Each assembly contains four independent check valves connected in a series-parallel configuration for added redundancy. The check valves provide a positive checking action against a reverse flow of propellant liquid and/or vapor, and permit helium pressure to be directed to the propellant tanks. Filters are incorporated in the inlet to each check valve assembly and each test port (figures 2.4-1 and 2.4-2).

2.4.2.1.5 Helium Pressure Relief Valves.

The pressure relief valves consist of a relief valve, a burst diaphragm, and a filter.

In the event excessive helium and/or propellant vapor ruptures the burst diaphragm, the relief valve opens and vents the applicable system. The relief valve will close and reseal after the excessive pressure has returned to the operating level. The burst diaphragm provides a more positive seal of helium than a relief valve. The filter prevents any fragments from the (nonfragmentation type) diaphragm from entering onto the relief valve seat.

A pressure bleed device is incorporated between the burst diaphragm and relief valve. The bleed valve vents the cavity between the burst diaphragm and relief valve in the event of any leakage from the diaphragm. The bleed device is normally open and will close when the pressure increases to a predetermined pressure.

A protective cover is installed over the relief valve vent port and bleed valve cavity port to prevent moisture accumulation and foreign matter entrance. The covers are left in place at lift-off.

2.4.2.1.6 Heat Exchangers.

Each unit is a line-mounted, counterflow heat exchanger consisting of the helium pressurization line coiled helically within an enlarged section of the propellant supply line. The helium gas, flowing through the coiled line, approaches the temperature of the propellant prior to entry into the respective storage tanks, thus reducing pressure excursions to a minimum.

2.4.2.2 Propellant Subsystem.

This subsystem consists of two fuel tanks (storage and sump), two oxidizer tanks (storage and sump), and propellant feed lines.

SYSTEMS DATA

2.4.2.2.1 Propellant Tanks.

The propellant supply is contained in four hemispherical-domed cylindrical tanks within the service module (figures 2.4-1, 2.4-2, and 2.4-3). The storage tanks are pressurized by the helium supply. An outlet transfers the propellant and/or helium gas from the storage tanks through their respective transfer lines to the sump tanks. A standpipe in the sump tanks allows the propellant and/or helium gas from the storage tanks to pressurize the sump tanks. The propellants in the sump tanks are directed into retention reservoirs, to the outlet, and to the engine.

The umbrella retention reservoir, can, and screens are installed in the exit end of the sump tanks. The reservoir retains a quantity of propellants at the exit end of the sump tanks and the engine plumbing during 0-g condition. The reservoir permits engine ignition when the SPS propellant quantity remaining is greater than 22,300 pounds (56.4%) without an ullage maneuver. An ullage maneuver is also required prior to any SPS thrusting period following all docked LM DPS burns even if the SPS propellant quantity remaining is at or greater than 22,300 pounds (56.4%). When the SPS propellant quantity remaining is at 22,300 pounds (56.4%) or less, an ullage maneuver is performed prior to an SPS engine thrusting period to ensure that gas is not retained aft of the screens.

2.4.2.2.2 Tank Propellant Feed Lines.

The propellant feed lines have flexible bellows assemblies installed to permit alignment of the tank feed plumbing to the engine interface plumbing.

2.4.2.3 Bipropellant Valve Assembly.

The bipropellant valve assembly consists of two gaseous nitrogen (GN₂) pressure vessels, two injector prevalues, two GN₂ regulators, two GN₂ relief valves, four solenoid control valves, four actuators, and eight bipropellant ball valves.

2.4.2.3.1 Gaseous Nitrogen (GN₂) Pressure Vessels.

Two GN₂ tanks are mounted on the bipropellant valve assembly to supply pressure to the injector prevalues. One GN₂ tank is in the primary pneumatic control system A and the remaining GN₂ tank is in the secondary pneumatic control system B.

SYSTEMS DATA

2.4.2.3.2 Injector Prevalves.

The injector prevalves are two-positive solenoid-operated valves, one for each pneumatic control system, and are identified as A and B. The valve is energized open and spring-loaded closed. The injector prevalves are controlled by the ΔV THRUST NORMAL switches on MDC-1. When switch A is placed to NORMAL, injector prevalve A is energized open. If switch B is placed to NORMAL, injector prevalve B is energized open. The injector prevalves, when energized open, allow GN₂ supply tank pressure to be directed through an orifice, into a regulator, relief valve, and to a pair of solenoid control valves. The solenoid control valves are controlled by the SPS thrust ON-OFF commands. The OFF position of the ΔV THRUST switches de-energizes the injector prevalves and springloads closed.

The ΔV THRUST NORMAL switch A receives power from SPS HE VALVE A circuit breaker on MDC-8 for control of the injector prevalve A. The ΔV THRUST NORMAL switch B receives power from SPS HE VALVE B circuit breaker on MDC-8 for control of the injector prevalve B (figures 2.4-1 and 2.4-2).

The ΔV THRUST NORMAL switches, A and/or B, also provide enabling power for the thrust ON-OFF logic circuitry.

2.4.2.3.3 GN₂ Filters (CSM 108 and Subs).

A filter is installed between each GN₂ pressure vessel and injector prevalve (figures 2.4-1 and 2.4-2). A filter is also installed on each GN₂ regulator outlet test port.

2.4.2.3.4 GN₂ Pressure Regulators.

A single-stage regulator is installed in each pneumatic control system between the injector prevalves and the solenoid control valves. The regulator reduces the supply GN₂ pressure to a desired working pressure.

2.4.2.3.5 GN₂ Relief Valves.

A pressure relief valve is installed in each pneumatic control system downstream of the GN₂ pressure regulators. This limits the pressure applied to the solenoid control valves in the event a GN₂ pressure regulator malfunctioned open.

SYSTEMS DATA

2.4.2.3.6 GN₂ Orifices.

The orifice between the injector prevalve and regulator is installed to restrict the flow of GN₂ and allow the relief valve to relieve the pressure overboard in the event the regulator malfunctions open, preventing damage to the solenoid control valves and/or actuators.

2.4.2.3.7 GN₂ Solenoid Control Valves.

Four solenoid-operated three-way two-position control valves are utilized for actuator control. Two solenoid control valves are located downstream of the GN₂ regulators in each pneumatic control system. The solenoid control valves in the primary system are identified as 1 and 2 and the two in the secondary system are identified as 3 and 4. The solenoid control valves in the primary system control actuator and ball valves 1 and 2. The two solenoid control valves in the secondary system control actuator and ball valves 3 and 4. The SPS thrust ON-OFF command controls the energizing or de-energizing of the solenoid control valves. Solenoid control valves 1 and 2 are energized by the SPS thrust ON-OFF command if ΔV THRUST NORMAL switch A is placed to A. Solenoid control valves 3 and 4 are energized by the SPS thrust ON-OFF command if ΔV THRUST NORMAL switch B is placed to B.

2.4.2.3.8 GN₂ Ball Valve Actuators.

Four piston-type, pneumatically operated actuators are utilized to control the eight propellant ball valves. Each actuator piston is mechanically connected to a pair of propellant ball valves, one fuel and one oxidizer. When the solenoid control valves are opened, pneumatic pressure is applied to the opening side of the actuators. The spring pressure on the closing side is overcome and the actuator piston moves. Utilizing a rack and pinion gear, linear motion of the actuator connecting arm is converted into rotary motion, which opens the propellant ball valves. When the engine firing signal is removed from the solenoid control valves, the solenoid control valves close, removing the pneumatic pressure source from the opening side of the actuators. The actuator closing side spring pressure now forces the actuator piston to move in the opposite direction, causing the propellant ball valves to close. The piston movement forces the remaining GN₂, on the opening side of the actuator, back through the solenoid control valves where it is vented overboard.

Each actuator incorporates a pair of linear position transducers. One supplies ball valve position information to the SPS ENGINE INJECTOR VALVES indicators on MDC-3. The output of the second transducer supplies ball valve position information to telemetry.

SYSTEMS DATA

2.4.2.3.9 Bipropellant Ball Valves.

The eight propellant ball valves are used to distribute fuel and oxidizer to the engine injector assembly. Each pair, of four linked pairs, consists of one fuel and one oxidizer ball valve that is controlled by a single actuator. The four linked pairs are arranged in a series-parallel configuration, figures 2.4-1 and 2.4-2. The parallel redundancy ensures engine ignition; the series redundancy ensures thrust termination. When GN₂ pressure is applied to the actuators, each propellant ball valve is rotated, aligning the ball to a position that allows propellants to flow to the engine injector assembly. The mechanical arrangement is such that the oxidizer ball valves maintain an 8-degree lead over the fuel ball valves upon opening, which results in smoother engine starting transients.

2.4.2.3.10 Bipropellant Valve Assembly Check Valves.

Check valves are installed in the vent port outlet of each of the four solenoid control valves, spring pressure vent port of the four actuators, and the ambient vent port of the two GN₂ pressure regulator assemblies. Thus, the seals of the components are protected from a hard vacuum in space.

2.4.2.3.11 Engine Propellant Lines.

Integral propellant lines are utilized on the engine to route each propellant from the interface points, in the gimbal plane area, to the bipropellant valve assembly. The plumbing consists of flexible bellows that permit propellant line flexibility for engine gimbaling, orifices for adjustment of oxidizer/fuel ratio, and screens to prevent particle contaminants from entering the engine.

2.4.2.4 Engine Injector.

The injector is bolted to the ablative thrust chamber attach pad. Propellant distribution through the injector is accomplished through concentric annuli machined orifices in the face of the injector assembly and covered by concentric closeout rings. Propellant distribution to the annuli is accomplished through alternate radial manifolds welded to the backside of the injector body. The injector is baffled to provide combustion stability. The fuel and oxidizer orifices impinge, atomize, and ignite because of hypergolic reaction.

2.4.2.5 Ablative Combustion Chamber.

The ablative combustion chamber material extends from the injector attach pad to the nozzle extension attach pad. The ablative material consists of a liner, a layer of insulation, and integral metal attach flanges for mounting the injector.

SERVICE PROPULSION SYSTEM

SYSTEMS DATA

2.4.2.6 Nozzle Extension.

The bell-contoured nozzle extension is bolted to the ablative thrust chamber exit area. The nozzle extension is radiant-cooled and contains an external stiffener to provide additional strength.

2.4.2.7 SPS Electrical Heaters.

There are six electrical heaters installed on the tank feed lines from the respective sump tank outlets to the interface flange, on the respective engine feed lines from the interface flange to the bipropellant valve assembly and on the bottom side of the bipropellant valve assembly (figures 2.4-4 and 2.4-5). Each heater contains a redundant element. These electrical heaters provide heat to the tank feed lines, engine feed lines and bipropellant valve assembly, thus to the propellants. The heaters are controlled as a normal manual function of the crew on MDC-3 (figure 2.4-6) utilizing the SPS LINE HTRS switch. When the switch is placed to position A/B, power is supplied to 12 elements. When the switch is placed to position A, power is supplied to 6 elements. The switch is placed to position A/B or A when the SPS PRPLNT TANKS TEMP indicator on MDC-3 reads +45° F. Temperature is derived from the engine fuel line temperature sensor (figure 2.4-1). The switch is placed to OFF when the indicator reads +75° F. The red-line markings on the indicator are +27° F and +100° F, respectively.

The engine oxidizer feed-line temperature (figures 2.4-1 and 2.4-2) may be utilized as a back-up to the SPS PRPLNT TANKS TEMP indicator on MDC-3. The engine oxidizer feed-line temperature may be monitored on MDC-101 (figure 2.4-7).

2.4.2.8 Thrust Mount Assemblies.

The thrust mount assembly consists of a gimbal ring, engine-to-vehicle mounting pads, and gimbal ring-to-combustion chamber assembly support struts. The thrust structure is capable of providing ±10 degrees inclination about the Z-axis and ±6 degrees about the Y-axis.

2.4.2.8.1 Gimbal Actuator.

Thrust vector control of the service propulsion engine is achieved by dual, servo, electromechanical actuators. The gimbal actuators are capable of providing control around the Z-Z axis (yaw) of ±4.5 (+0.5, -0.0) degrees in either direction from a +1-degree null offset during SPS thrusting periods (0-degree null offset during non SPS thrusting periods), and around the Y-Y axis (pitch) of ±4.5 (+0.5, -0.0) degrees in either direction from a +2-degree null offset during SPS thrusting periods (+1.5-degree null offset during non SPS thrusting periods).

SYSTEMS DATA

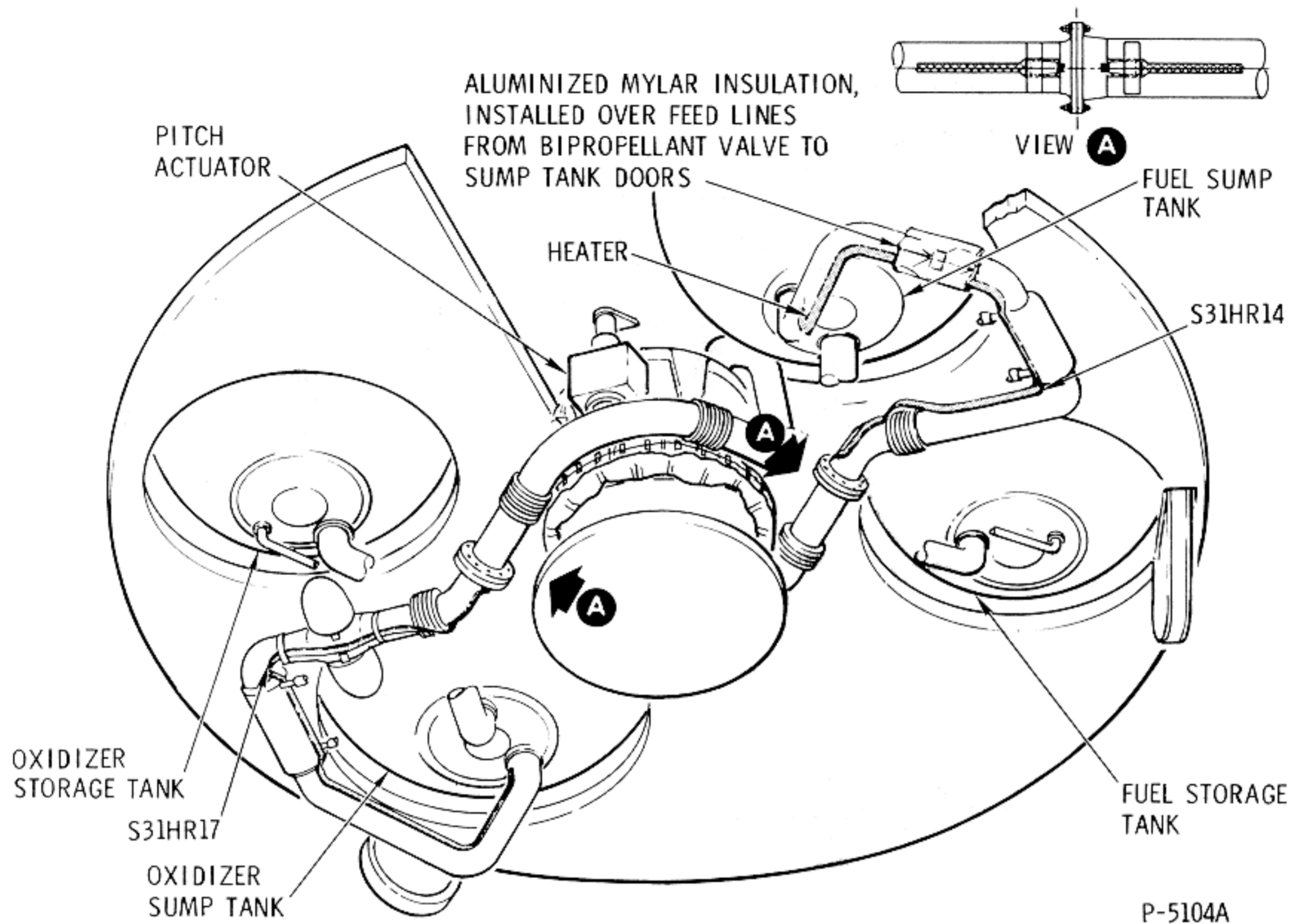

Figure 2.4-4. SPS Heater Installation, Tank Feed Lines

The reason for the +1-degree null offset to the +Y axis and +2-degree offset to the +Z axis during SPS thrusting periods, is the offset center of mass. The reason for the change in the null offset positions from an SPS non-thrusting period to an SPS thrusting period is due to the structural and engine deflections that occur when thrust-on is provided to the SPS engine.

Each actuator assembly (figure 2.4-8) consists of four electromagnetic particle clutches, two d-c motors, a bull gear, jack-screw and ram, ball nut, two linear position transducers, and two velocity generators. The actuator assembly is a sealed unit and encloses those portions protruding from the main housing.

One motor and a pair of clutches (extend and retract) are identified as system No. 1, the remaining motor and pair of clutches (extend and retract) are identified as system No. 2 within the specific actuator.

SYSTEMS DATA

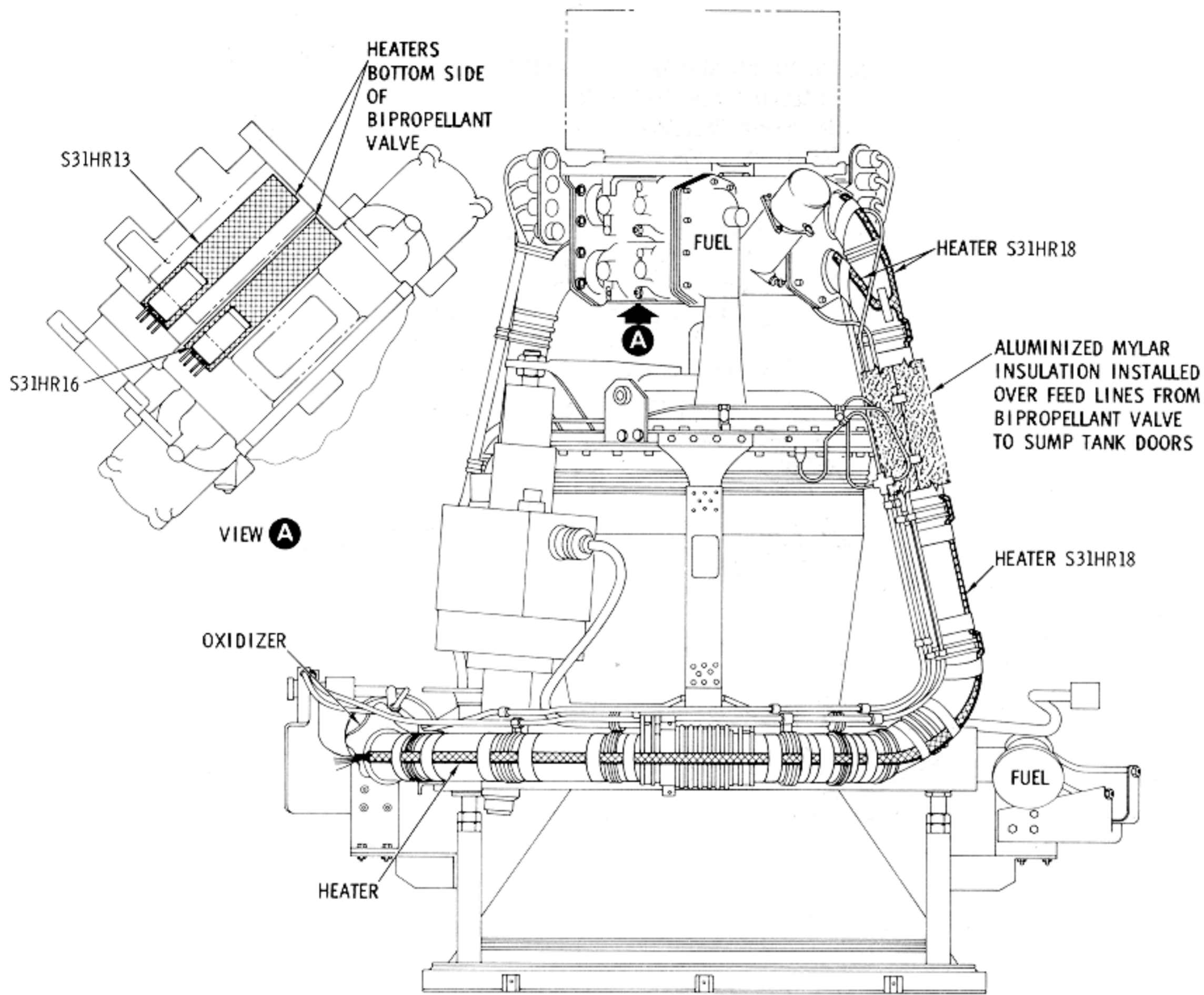

P-5105A

Figure 2.4-5. SPS Heater Installation, Engine Feed Lines

An overcurrent monitor circuit is employed for each primary and secondary gimbal motor. Each gimbal motor and overcurrent monitor circuit is controlled by its own SPS GIMBAL MOTORS switch on MDC-1. There are four SPS GIMBAL MOTORS switches, PITCH 1 and 2 and YAW 1 and 2. Figure 2.4-9 illustrates the yaw actuator as an example. When the SPS GIMBAL MOTORS YAW 1 (primary) switch is positioned to START, power is applied from the battery bus to the motor-driven switch. The motor-driven switch closes a contact that allows power from the main bus to the gimbal motors. Thus, the gimbal motor is started. When the SPS GIMBAL MOTORS YAW 1 switch is released, it springs back to the center position. The center position activates the overcurrent monitor sensing circuitry. The SPS GIMBAL MOTORS YAW 2 (secondary) switch is then positioned to START. The SPS GIMBAL MOTORS YAW 2 switch activates yaw 2 motor-driven switch. The motor-driven switch of YAW 2 functions as with YAW 1. The SPS GIMBAL MOTORS YAW 2 switch released from START, spring loads to center. The center position activates the overcurrent monitor circuit of yaw 2.

SM2A-03-BLOCK II-(1)
 APOLLO OPERATIONS HANDBOOK

SYSTEMS DATA

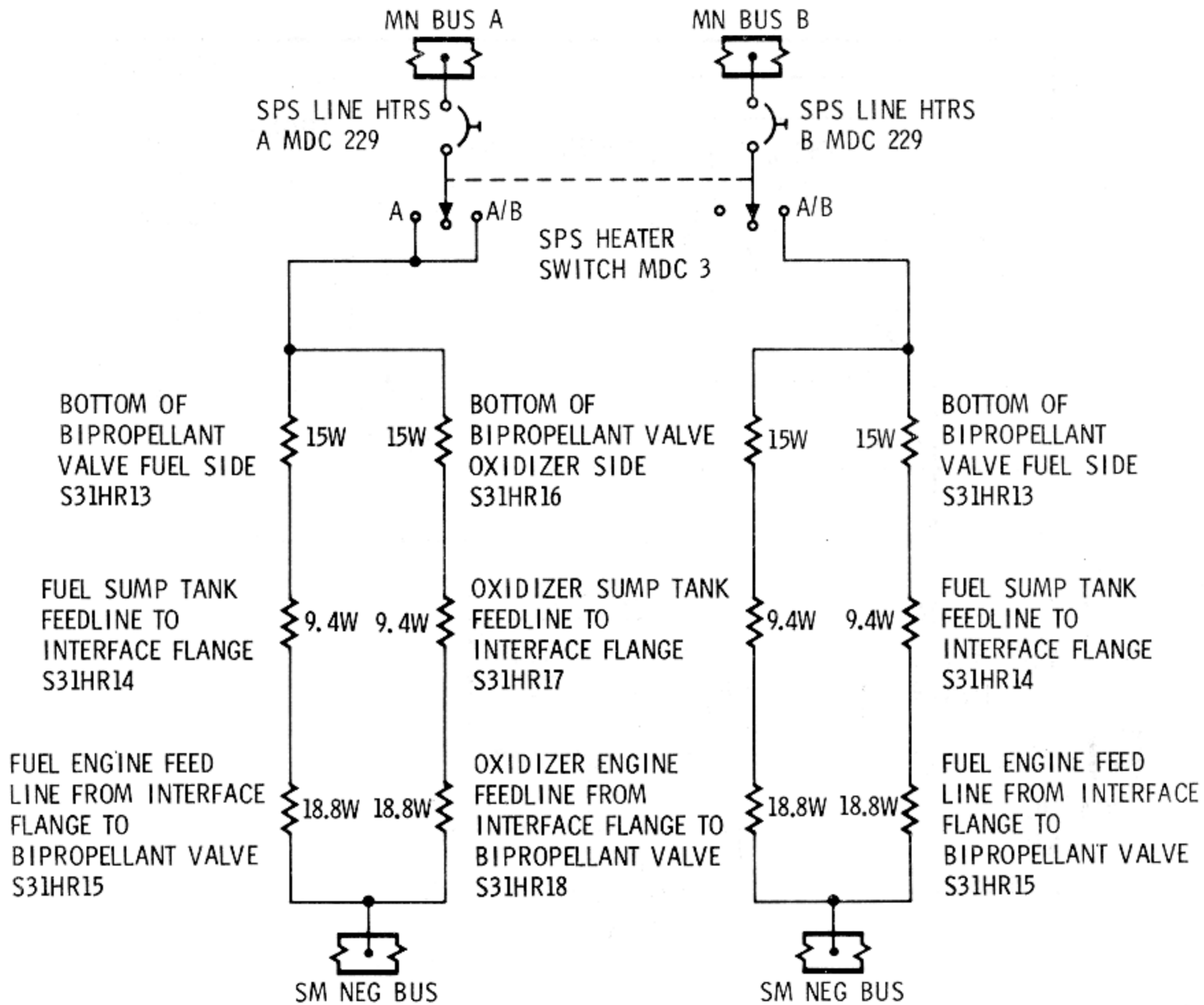

SPS

P-5103B

Figure 2.4-6. SPS Electrical Heaters

The overcurrent monitor circuits of the primary and secondary system are utilized to monitor the current to the gimbal motors. This is because of the variable current flow during the initial gimbal motor start, normal operation for the main d-c bus, and gimbal motor protection.

Using the No. 1 yaw system as an example, identify the upper motor and clutches in figures 2.4-8 and 2.4-9 as system No. 1. When the overcurrent monitoring senses an overcurrent on gimbal motor No. 1, the following functions occur. The overcurrent monitor circuitry drives the motor-driven switch. This removes power from gimbal motor No. 1, rendering it inoperative. Simultaneously, a signal is sent to illuminate

SERVICE PROPULSION SYSTEM

SYSTEMS DATA

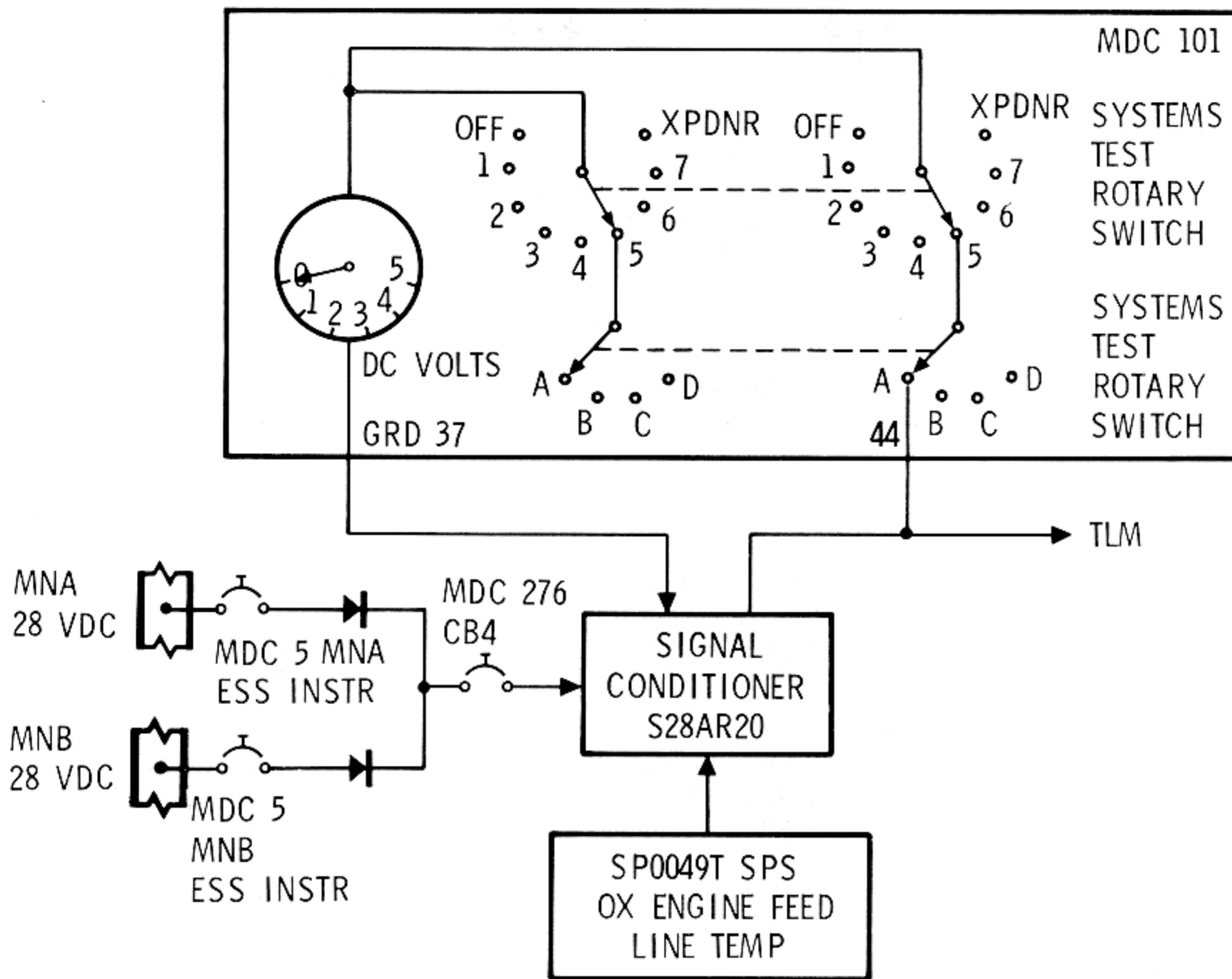

P-5097B

Figure 2.4-7. SPS Oxidizer Engine Feed-Line Temperature Monitoring

the YAW GMBL DR 1 caution and warning light on MDC-2. This informs the crew the YAW gimbal motor No. 1 has failed due to overcurrent. Simultaneously, a fail sense signal is sent from a contact on the motor-driven switch. The fail sense signal is sent through an OR and AND gate to a solid-state switch. This switch provides a ground for relay coils A4K4, A4K5, A4K6 and A4K8. These relays are energized if the TVC GMBL DRIVE YAW switch on MDC-1 is in AUTO and the SCS TVC SERVO POWER switch 2 on MDC-7 is in AC2/MNB or AC1/MNA. This allows the upper relay contacts of A4K4 and A4K8 to open and removes the power input to the No. 1 clutches.

SYSTEMS DATA

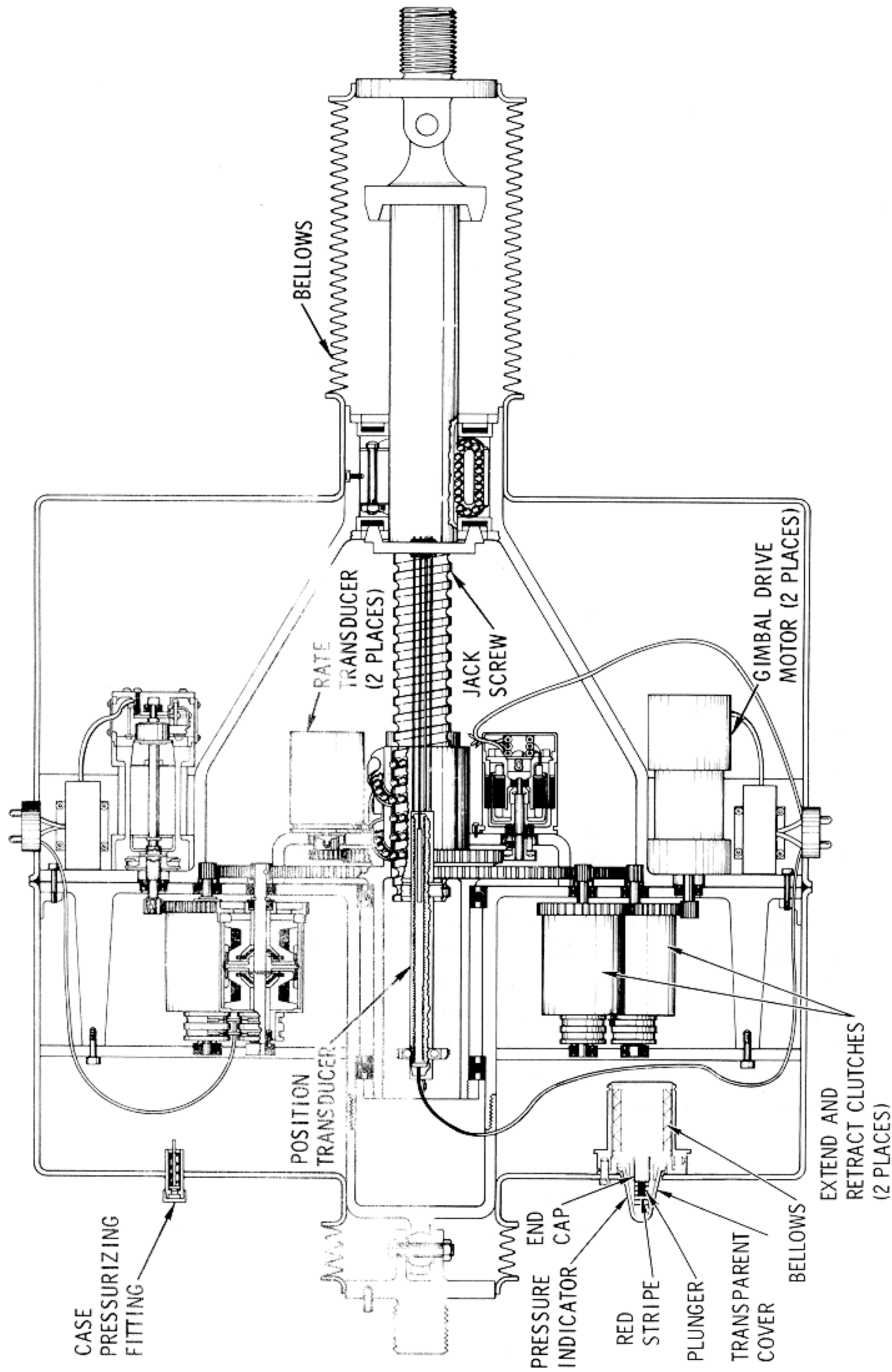

P-5017A

Figure 2.4-8. SPS Electromechanical Gimbal Actuator

SERVICE PROPULSION SYSTEM

SM2A-03-BLOCK II-(1)
APOLLO OPERATIONS HANDBOOK

SYSTEMS DATA

Simultaneously, the lower relay contacts of A4K5 and A4K8 close. This applies power inputs to the No. 2 clutches within the same actuator. Simultaneously, the upper contacts of A4K4, A4K5, and A4K6 open and the lower contacts close, allowing thrust vector control monitoring. The SPS GIMBAL MOTORS YAW 1 switch on MDC-1 is then positioned to OFF. Normally, the OFF position is used to shut down the gimbal motor upon completion of a thrusting period.

Using No. 2 yaw system as an example, identify the lower motor and clutches in figure 2.4-8 and 2.4-9 as system No. 2. When the overcurrent monitoring senses an overcurrent on gimbal motor No. 2, the following functions occur. The overcurrent monitor circuitry will drive the motor-driven switch. This removes power from gimbal motor No. 2, rendering it inoperative. Simultaneously, a signal is sent to illuminate the YAW GMBL DR 2 caution and warning light on MDC-2. This informs the crew the YAW gimbal motor No. 2 has failed due to overcurrent. There is no fail sense signal sent to control relay coils A4K4, A4K5, A4K6, and A4K8. If the No. 2 gimbal motor has failed as well as No. 1 gimbal motor, that specific actuator is inoperative. The SPS GIMBAL MOTORS YAW 2 switch on MDC-1 is then positioned to OFF. Normally, the OFF position is used to shut down the gimbal motor upon completion of a thrusting period.

The LV/SPS IND switch on MDC-1 when positioned to GPI de-energizes relay coils A11K3, A11K4, A11K5, and A11K6 (figure 2.4-9). This allows the relay contact points of A11K3, A11K4, A11K5, and A11K6 to move to the down position. The actuator position transducer is then allowed to transmit gimbal position information to the SPS GPI on MDC-1.

The TVC GMBL DRIVE YAW switch on MDC-1 will also control through the OR and AND gate the solid-state switch (figure 2.4-9). The solid-state switch will provide the ground for relay coils A4K4, A4K5, A4K6, and A4K8. The power input to these relays is provided by positioning the TVC SERVO POWER switch 2 on MDC-7 to AC2/MNB or AC1/MNA. When the TVC GMBL DRIVE YAW switch is in AUTO, the primary gimbal motor overcurrent monitor circuitry controls the solid-state-switch. If overcurrent on the primary gimbal motor is sensed, the CMC, SCS or MTVC inputs are switched automatically from the primary to the secondary clutches.

If the TVC GMBL DRIVE YAW switch on MDC-1 is in position 1, the CMC, SCS, or MTVC inputs are locked into the primary clutches. If overcurrent is sensed on gimbal motor No. 1, or if the translation control is rotated clockwise, there is no automatic switchover from the primary to secondary clutches. The TVC GMBL DRIVE YAW switch positioned to 1 could be utilized to check out gimbal motor No. 1, the primary clutches, and the primary servo loop system.

SERVICE PROPULSION SYSTEM

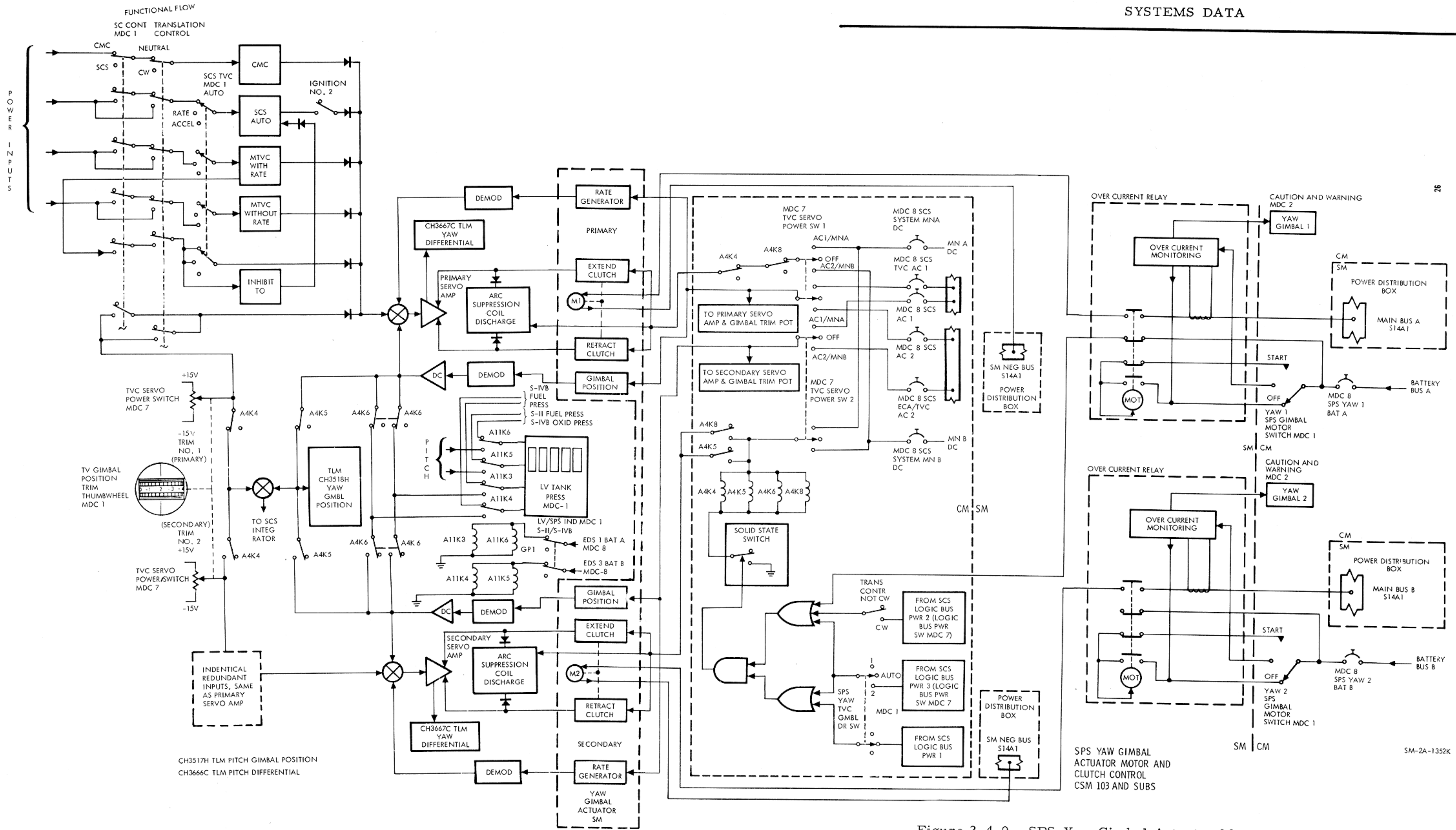

Figure 2.4-9. SPS Yaw Gimbal Actuator Motor and Clutch Control

SM2A-03-BLOCK II-(1)
APOLLO OPERATIONS HANDBOOK

SYSTEMS DATA

If the TVC GMBL DRIVE YAW switch on MDC-1 is in position 2 and the TVC SERVO POWER switch 2 on MDC-7 is in AC2/MNB or AC1/MNA position. The CMC, SCS or MTVC inputs are locked into the secondary clutches. This position could be utilized to check out gimbal motor No. 2, the secondary clutches, and the secondary servo loop system.

If the TVC GMBL DRIVE YAW switch on MDC-1 is in AUTO and TVC SERVO POWER switch 2 on MDC-7 is in AC2/MNB or AC1/MNA position. The SCS or MTVC inputs are removed from the primary clutches and switched to the secondary clutches when the translation control is rotated clockwise.

The pitch gimbal actuator operation and control function in the same manner as yaw. The pitch gimbal actuator control circuits has its own PITCH GIMBAL MOTOR switches on MDC-1 and its own TVC GMBL DR PITCH switch on MDC-1. The TVC SERVO POWER switches on MDC-7 will supply power to the pitch clutches as in the case of the yaw clutches. The LV/SPS IND switch to GPI on MDC-1 allows pitch gimbal position to the GPI. The relay coils, however, will have different numbers in the pitch actuator.

It is noted that the primary yaw and pitch gimbal motor receive power from MN BUS A. The primary pitch and yaw motor-driven switches receive power from BAT BUS A. The secondary yaw and pitch gimbal motors receive power from MN BUS B. The secondary pitch and yaw motor-driven switches receive power from BAT BUS A.

The clutches are of a magnetic-particle type. The gimbal motor drive gear meshes with the gear on the clutch housing. The gears on each clutch housing mesh and as a result, the clutch housings counter rotate. The current input is applied to the electromagnet mounted to the rotating clutch housing from the SCS, CMC, or MTVC. A quiescent current may be applied to the electromagnet of the extend and retract clutches when the TVC SERVO POWER switches, on MDC-7, are in AC1/MNA or AC2/MNB, preventing any movement of the engine during the boost phase of the mission with the gimbal motors OFF. The gimbal motors will be turned ON prior to jettisoning the launch escape tower to support the SPS abort after the launch escape tower has been jettisoned and will be turned OFF as soon as possible to reduce the heat that occurs due to the gimbal motor driving the clutch housing with quiescent current applied to the clutch. The friction force in the clutch housing creates heat which if allowed to increase to a high temperature, the electromagnet would lose its magnetism capability, thus rendering that set of clutches inoperative.

SERVICE PROPULSION SYSTEM

SM2A-03-BLOCK II-(1)
APOLLO OPERATIONS HANDBOOK

SYSTEMS DATA

Prior to any SCS ΔV thrusting period or in MTVC (manual thrust vector control), the thumbwheels on MDC-1 will be used to position the engine. The thumbwheels may be positioned prior to any CMC ΔV thrusting period but cannot position the engine. In any thrusting mode, the current input required for a gimbal angle change (to maintain the engine thrust vector through the center of mass) to the clutches will increase above the quiescent current. This increases the current into the electromagnets that are rotating with the clutch housings. The dry powder magnetic particles have the ability to become magnetized very readily, as well as demagnetized just as readily. The magnetic particles increase the friction force between the rotating housing and the flywheel, causing the flywheel to rotate. The flywheel arrangement is attached to the clutch output shaft allowing the clutch output shaft to drive the bull gear. The bull gear drives a ball nut which drives the actuator jackshaft to an extend or retract position, depending upon which clutch housing electromagnet the current input is supplied to. The larger the excitation current, the higher the clutch shaft rotation rate.

Meshed with the ball nut pinion gear are two rate transducers. The transducers are a tachometer type. When the ball nut is rotated, the rate transducer supplies a feedback into the summing network of the thrust vector control logic to control the driving rates of the jackscrew (acting as a dynamic brake to prevent over- or under-correcting). There is one rate transducer for each system.

The jackscrew contains two position transducers, all arranged for linear motion and all connected to a single yoke. The position transducers are used to provide a feedback to the summing network and the visual display on MDC-1. The operating system provides feedback into the summing network reducing the output current to the clutch resulting in proportional rate change to the desired gimbal angle position and returns to a quiescent current in addition to providing a signal to the visual display on MDC-1.

The remaining position transducer provides a feedback to the redundant summing network of the thrust vector logic for the redundant clutches in addition to the visual display on MDC-1 if the secondary system is the operating system.

The spacecraft desired motion, thumbwheel positioning, rotation control (MTVC), engine nozzle position, thrust vector position, gimbal position display indicator, and actuator ram movement is identified in figures 2.4-10 and 2.4-11.

A snubbing device provides a hard stop for an additional one-degree travel beyond the normal gimbal limits.

SYSTEMS DATA

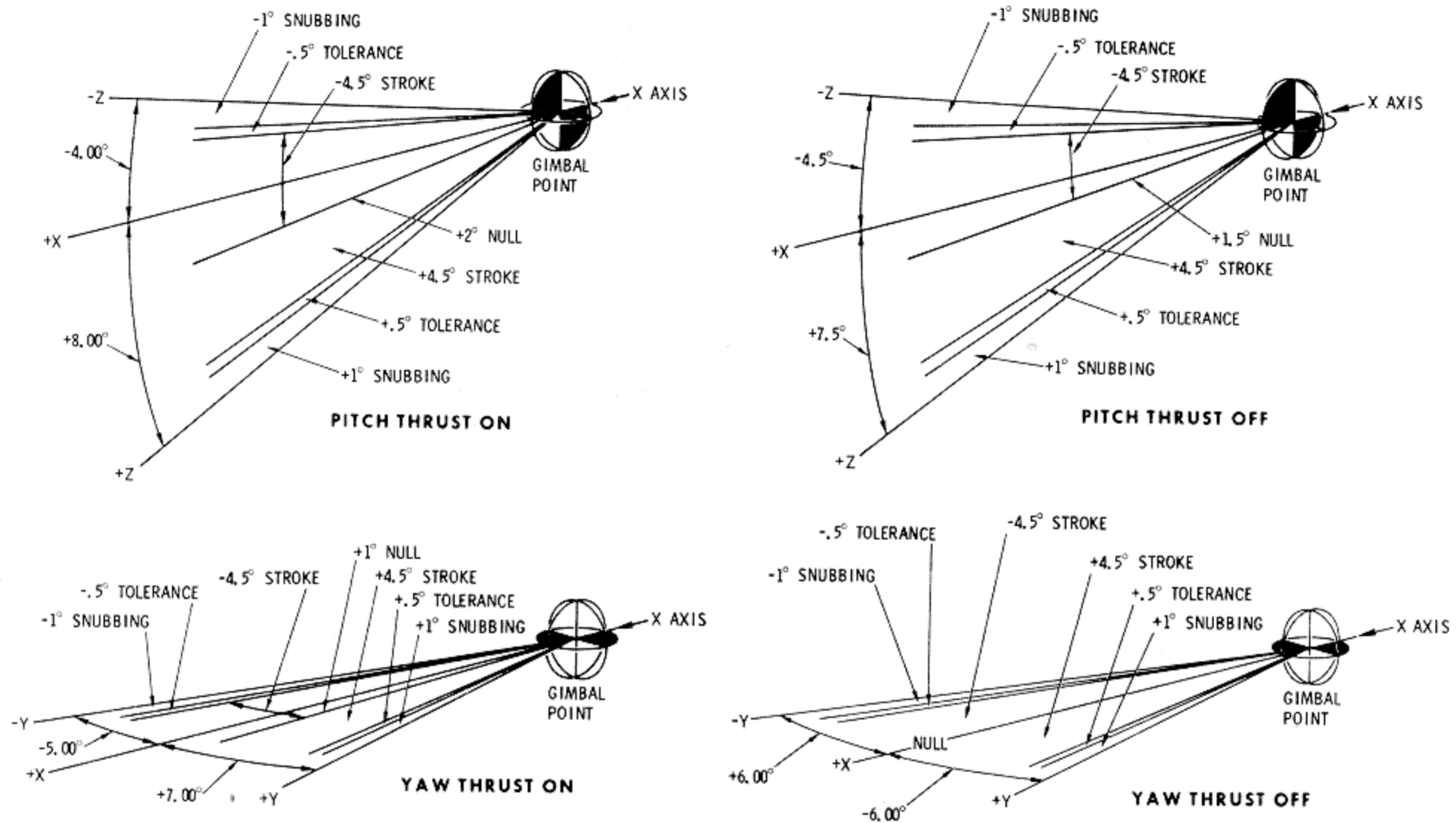

SPS

THE ENGINE MOUNTING PADS IN THE SERVICE MODULE ARE CANTED 4° (THRUST VECTOR) TO THE +Y AXIS OF THE SPACECRAFT. HOWEVER THE ACTUATOR NULL ADJUSTMENTS ARE AS FOLLOWS:

PITCH

THE PITCH ACTUATOR NULL POSITION IS +2° THRUST VECTOR TO THE +Z, ENGINE NOZZLE -2° TO THE -Z DURING AN SPS ENGINE FIRING. THE NULL POSITION IS +1.5° THRUST VECTOR TO THE +Z, ENGINE NOZZLE -1.5° TO THE -Z DURING SPS NON-THRUSTING PERIODS. THE THUMB WHEEL ON MDC 1 & GIMBAL POSITION INDICATOR/FUEL PRESSURE INDICATOR ON MDC 1 WILL BE 0.0°.

YAW

THE YAW ACTUATOR NULL POSITION IS +1° THRUST VECTOR TO THE +Y, ENGINE NOZZLE IS -1° TO THE -Y DURING AN SPS ENGINE FIRING. THE NULL POSITION IS 0° THRUST VECTOR TO THE Y, ENGINE NOZZLE IS 0° TO THE Y AXIS DURING SPS NON-THRUSTING PERIODS. THE THUMB WHEEL ON MDC 1 & GIMBAL POSITION INDICATOR/FUEL PRESSURE INDICATOR ON MDC 1 WILL BE 0.0°

THE REASON FOR THE DIFFERENCE BETWEEN A NON SPS ENGINE FIRING VERSUS AN SPS ENGINE FIRING IS DUE TO DEFLECTIONS OF ENGINE AND VEHICLE STRUCTURE.

P-5073F

Figure 2.4-10. SPS Angles Pitch and Yaw

2.4.2.9 Propellant Utilization and Gauging Subsystem (PUGS).

The subsystem consists of a primary and auxiliary sensing system, a propellant utilization valve, a control unit, and a display unit (figures 2.4-12 and 2.4-13).

2.4.2.9.1 Quantity Sensing, Computing, and Indicating System.

Propellant quantity is measured by two separate sensing systems, primary and auxiliary. The primary quantity sensors are cylindrical capacitance probes, mounted axially in each tank. In the oxidizer tanks,

SERVICE PROPULSION SYSTEM

SYSTEMS DATA

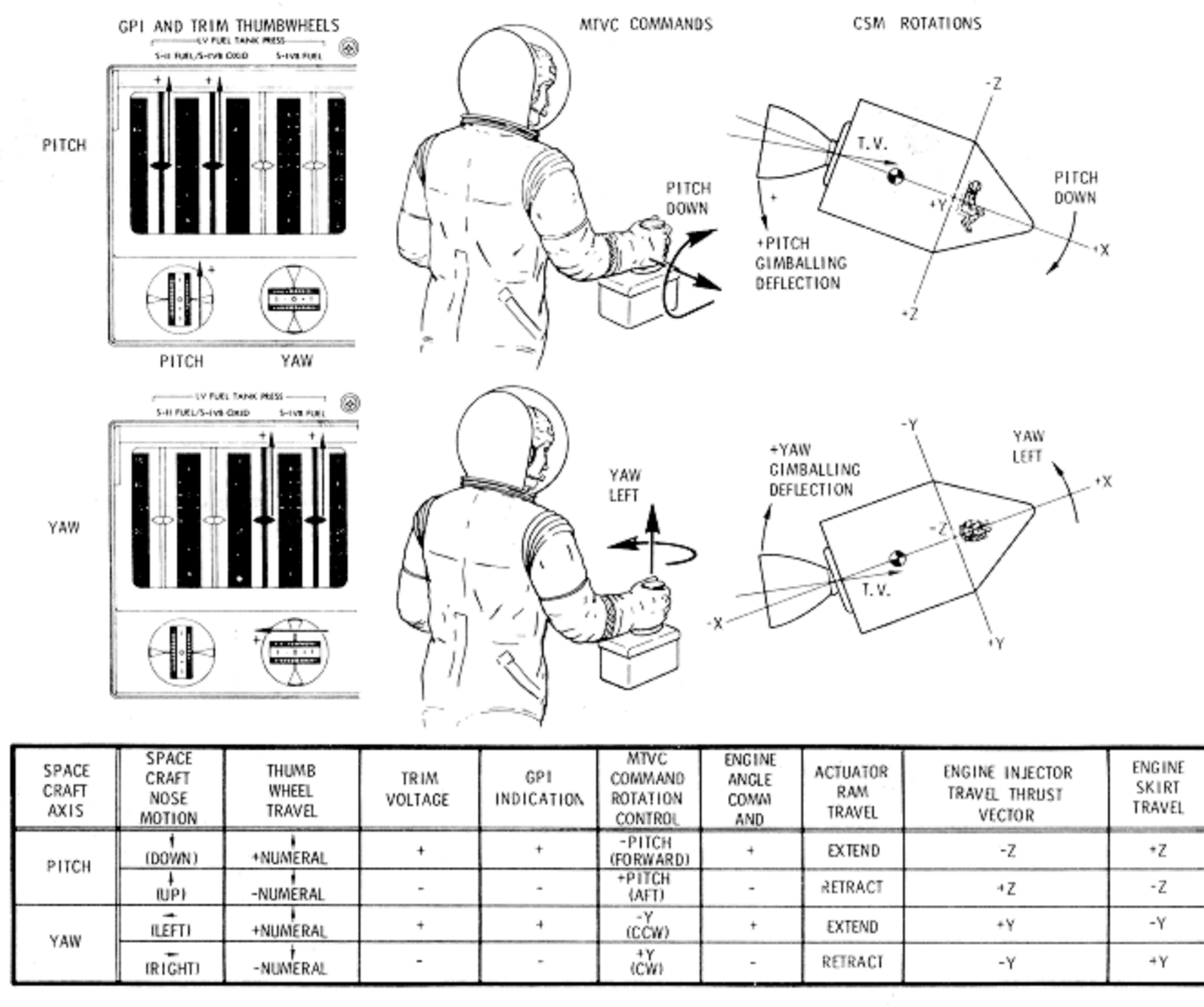

Figure 2.4-11. SPS Gimbaling

the probes consist of a pair of concentric electrodes with oxidizer used as the dielectric. In the fuel tanks, a pyrex glass probe, coated with silver on the inside, is used as one conductor of the capacitor. Fuel on the outside of the probe is the other conductor. The pyrex glass itself forms the dielectric. The auxiliary system utilizes point sensors mounted at intervals along the primary probes to provide a step function impedance change when the liquid level passes their location centerline.

Primary propellant measurement is accomplished by the probes capacitance, being a linear function of propellant height.

Auxiliary propellant measurement is accomplished by locating the propellant level with point sensors, seven in the storage tanks and eight in the sump tanks. Each point sensor consists of concentric metal rings. The rings present a variable impedance depending on whether they are covered or uncovered by the propellants. When the propellants are between point sensors, the propellants remaining are integrated by a rate flow generator which integrates the servos at a rate proportional to the nominal flow rate of the fuel and oxidizer. A mode selector senses when

SYSTEMS DATA

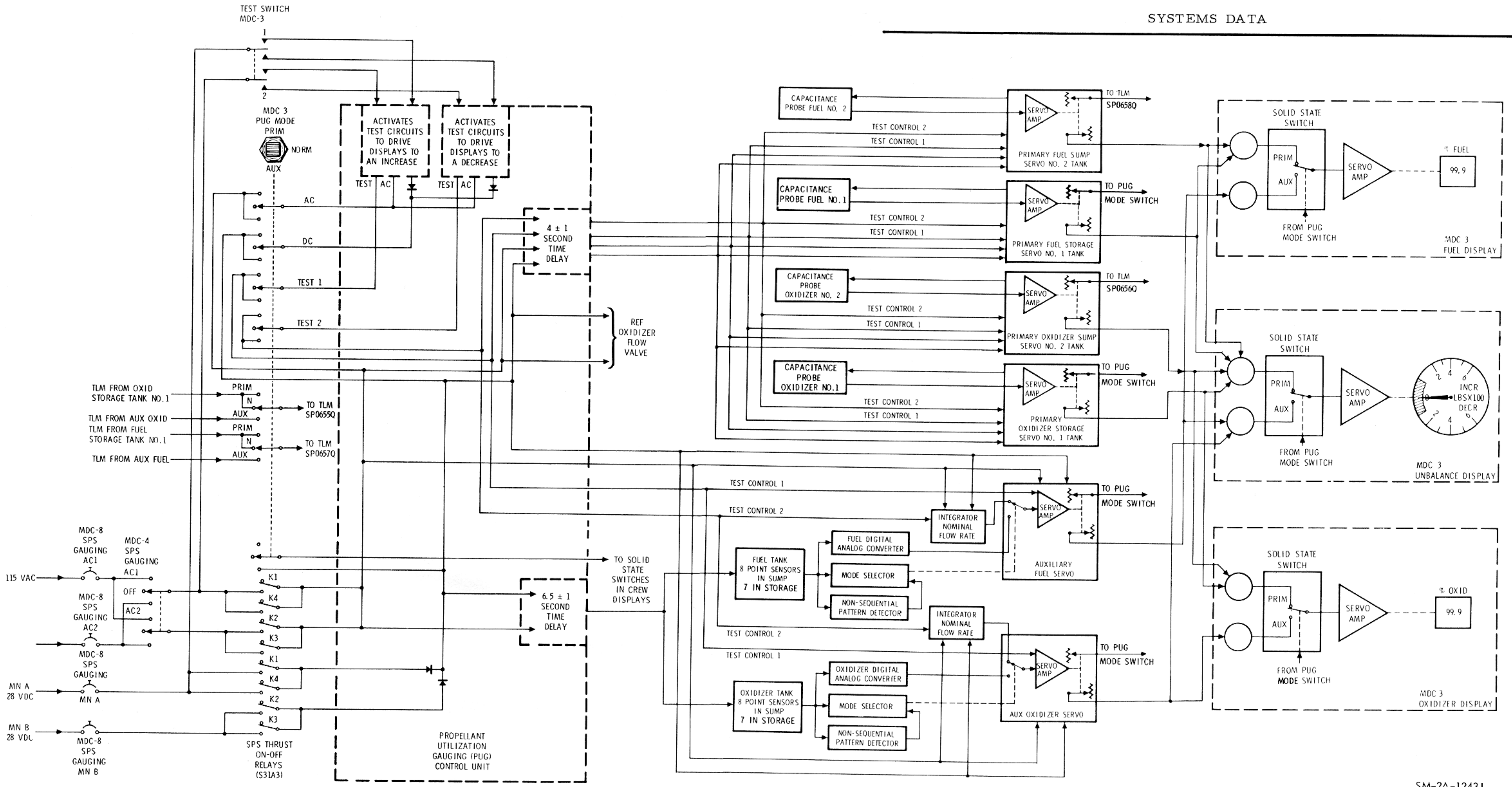

SM-2A-1243J

Figure 2.4-12. SPS Quantity, Sensing, Computing and Indicating System

SERVICE PROPULSION SYSTEM

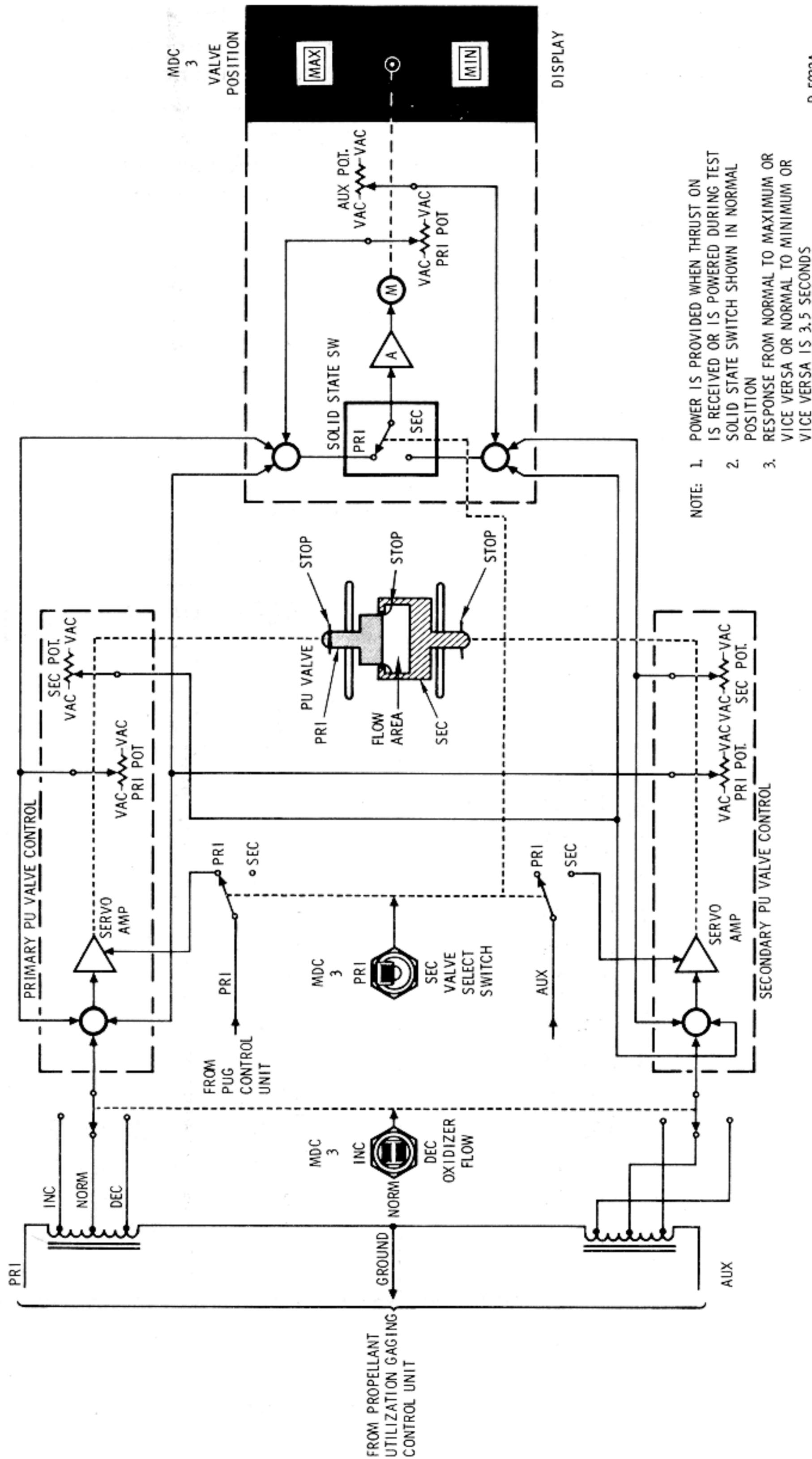

2.4-13. Propellant Utilization Valve and Flag Display

SPS

SM2A-03-BLOCK II-(1)
 APOLLO OPERATIONS HANDBOOK

SYSTEMS DATA

the propellant crosses a sensor and changes the auxiliary servos from the flow rate generator mode to the position mode, the system moves to the location specified by the digital-to-analog converter for 0.9 seconds to correct for any difference. The system then returns to the flow rate generator mode until the next point sensor is reached. Figures 2.4-14 and 2.4-15 identify the point sensor locations. The non-sequential pattern detector functions to detect false or faulty sensor signals. If a sensor has failed, the information from that sensor is blocked from the system, preventing disruption of system computation.

When a THRUST-ON signal is provided with the PUG MODE switch in the PRIMARY or NORMAL position, the crew display digital readouts and unbalance display will not change for 4±1 seconds to allow for propellant settling. However, TLM will receive the same signal as upon completion of the last firing after approximately one second of SPS THRUST-ON.

OXIDIZER POINT SENSOR LOCATIONS					
NUMBER	WEIGHT POUNDS		PERCENT MAXIMUM		INCHES
	TEMP	70°F	70°F		
	PRESS.	176.60 PSIA	176.60 PSIA		
15		1,586.01	6.5	} OXIDIZER SUMP TANK NO. 2	25.36
14		3,172.02	13.0		41.34
13		4,758.03	19.5		57.25
12		6,344.04	26.0		72.07
11		7,930.05	32.5		86.89
10		9,516.06	39.0		101.72
9		11,102.07	45.5		116.54
8		12,688.08	52.0		131.60
7		14,274.09	57.8		10.50
6		15,860.10	64.3		30.57
5		17,446.11	70.8	} OXIDIZER STORAGE TANK NO. 1	49.55
4		19,032.13	77.3		68.54
3		20,618.14	83.8		87.52
2		22,204.15	90.3		106.51
1		23,790.16	96.8		125.49

P-5093E

Figure 2.4-14. SPS Oxidizer Point Sensor Location

SERVICE PROPULSION SYSTEM

SM2A-03-BLOCK II-(1)
APOLLO OPERATIONS HANDBOOK

SYSTEMS DATA

FUEL POINT SENSOR LOCATIONS					
NUMBER	WEIGHT POUNDS		PERCENT MAXIMUM		
	TEMP	70°F	70°F		
	PRESS.	176.60 PSIA			
			INCHES		
15	992.08	6.5	} FUEL SUMP TANK NO. 2	25.36	
14	1984.16	13.0		41.34	
13	2976.24	19.5		57.25	
12	3968.32	26.0		72.07	
11	4960.40	32.5		86.89	
10	5952.48	39.0		101.72	
9	6944.56	45.5		116.54	
8	7936.64	52.0		131.60	
7	8928.72	57.8		} FUEL STORAGE TANK NO. 1	10.48
6	9920.80	64.3			30.55
5	10912.88	70.8	49.54		
4	11904.96	77.3	68.52		
3	12897.04	83.8	87.51		
2	13889.12	90.3	106.49		
1	14881.20	96.8	125.48		

SPS

P-5094F

Figure 2.4-15. SPS Fuel Point Sensor Location

When the THRUST-ON signal is provided with the PUG MODE switch in AUXILIARY position, the crew display digital readouts, unbalance display, and TLM will receive a change in information immediately, which is generated from a flow rate integrator that simulates the nominal flow rate and transmits this as quantity information to the crew displays and TLM. The crew digital readouts unbalance display and TLM will not be updated to the propellant from a point sensor for 6.5 ± 1.0 seconds after THRUST-ON. When the THRUST-ON signal is provided plus 6.5 ± 1.0 seconds, if a point sensor is uncovered, the crew digital readouts, unbalance display, and TLM will be updated to the propellant remaining at that point sensor. The time delay of 6.5 ± 1.0 seconds is to the point sensor system and not to the auxiliary fuel and oxidizer servos, and is to allow for propellant settling.

SERVICE PROPULSION SYSTEM

SM2A-03-BLOCK II-(1)
APOLLO OPERATIONS HANDBOOK

SYSTEMS DATA

Any deviation from the nominal oxidizer to fuel ratio (1.6:1 by mass) is displayed by the UNBALANCE indicator in pounds. The upper half of the indicator is marked INC and the lower half is marked DEC to identify the required change in oxidizer flow rate to correct any unbalance condition. The marked or shaded area is a normal unbalance range area.

The crew can determine if a true unbalance of propellant remaining exists. With the PUG mode switch in PRIM or NORM, the crew display percentage readouts would not indicate the same percentage value and the unbalance meter would indicate the amount of unbalance in pounds. To verify if a true unbalance condition exists, the PUG mode switch would be positioned to AUX. If the crew display percentage readouts and the

Figure 2.4-16. Deleted

SERVICE PROPULSION SYSTEM

SM2A-03-BLOCK II-(1)
APOLLO OPERATIONS HANDBOOK

SYSTEMS DATA

unbalance meter now read similar to the readouts when in PRIM, a true unbalance condition exists.

The crew can determine in the case of a malfunction as to what has malfunctioned within the quantity and indicating systems by utilization of the TEST switch. To test the PRIM gauging system, the PUG mode switch must be in PRIM, and to test the AUX gauging system, the PUG mode switch must be in AUX.

By observing the response of each system in conjunction with the test switch on MDC-3, the crew can recognize the malfunction or determine if there is a true unbalance existing.

The crew display readouts and unbalance meter should not be considered accurate until the SPS engine is thrusting for at least 25 seconds. This is to allow complete propellant settling in the SPS tanks before the gauging system is within its design accuracy.

When the THRUST-OFF signal is provided, regardless of the PUG MODE switch position, the visual display fuel and oxidizer percentage readouts and the unbalance meter display will lock at the readings displayed. TLM will not receive any propellant quantity information during THRUST-OFF conditions.

2.4.2.9.2 Quantity Computing and Indicating System Test.

A test of the sensing systems, excluding the point sensor and probes, can be implemented during THRUST-ON or OFF periods. With the PUG MODE switch in PRIM and the TEST switch in TEST 1 (up) position, the test stimuli is applied to the primary system tank servoamplifiers (4) after a time delay of 4±1 seconds. At this time, the test stimuli will drive the crew display fuel and oxidizer readouts to an increase reading at different rates. This results in an unbalance and is so indicated on the unbalance meter crew display as an INC (clockwise rotation). TLM would receive an increase in propellant quantity from the primary system tank servoamplifiers TLM potentiometers. When the TEST switch is released from TEST 1 (up) position, the TEST switch spring loads to the center position. This removes the test stimuli, and the crew displays will lock at the readings that they had been driven to. TLM would not receive any propellant quantity information.

With the PUG MODE switch in PRIM and positioning the TEST switch to the TEST 2 (down) position. The test stimuli is applied to the primary system tank servoamplifiers (4) after a time delay of 4±1 seconds. At this time, the test stimuli drives the crew display fuel and

SERVICE PROPULSION SYSTEM

SP

SM2A-03-BLOCK II-(1)
APOLLO OPERATIONS HANDBOOK

SYSTEMS DATA

oxidizer readouts to a decrease reading at different rates. This returns the crew displays close to the reading displayed prior to TEST 1 (up). Simultaneously TLM would receive the same information. The crew displays would lock at the new readings if the TEST switch is released to center (spring loaded). TLM would not receive any propellant quantity information at this time. If the TEST switch is positioned again to TEST 2 (down), followed by a time delay of 4+1 seconds, the fuel and oxidizer crew display readouts would drive to a decrease reading at different rates. This results in an unbalance condition and is so indicated on the unbalance meter display as a DEC (counterclockwise rotation). TLM would receive a decrease in propellant quantity at this time. Releasing the TEST switch to the center position removes the test stimuli and locks the displays at the new reading. TLM would not receive any propellant quantity information at this time. To return to the reading displayed prior to the second TEST 2 (down) the TEST switch is positioned to TEST 1 (up). After a time delay of 4+1 seconds, the crew displays would drive to an increase reading at different rates. This returns the crew displays close to the reading displayed prior to the second TEST 2 (down). At this time, TLM receives the same information.

To TEST the auxiliary system, the PUG MODE switch is positioned to AUX and the TEST switch set to TEST 1 (up) and TEST 2 (down) positions. There are no time delays involved with the auxiliary system.

With the PUG MODE switch in AUX, and positioning the TEST switch in the TEST 1 (up) position, the test stimuli is provided to the auxiliary fuel and oxidizer servoamplifiers (2). This drives the fuel and oxidizer displays to an increase reading at approximately the same rates. This results in no or a very small unbalance and is so indicated on the unbalance meter. At this time TLM would receive an increase in propellant quantity from the auxiliary system TLM potentiometers. Releasing the TEST switch to center, removes the test stimuli. The crew displays lock at whatever readings they had been driven to. TLM would not receive any information of propellant quantity at this time.

With the PUG MODE switch in AUX and positioning the TEST switch in the TEST 2 (down) position, the test stimuli is provided to the auxiliary fuel and oxidizer integrators. This drives the fuel and oxidizer displays to a decrease reading at the same rates. This returns the crew displays close to the readings displayed prior to TEST 1 (up). The result is no or very little unbalance and is so indicated on the unbalance meter crew display. At this time TLM would receive the same information. Releasing the TEST switch to center, the test stimuli is removed. This locks the crew displays, and TLM would not receive any propellant

SERVICE PROPULSION SYSTEM

SM2A-03-BLOCK II-(1)
APOLLO OPERATIONS HANDBOOK

SYSTEMS DATA

quantity information. If the TEST switch is positioned again to TEST 2 (down), the fuel and oxidizer crew displays would drive to a decrease reading at the same rates resulting in no or very little unbalance. TLM would receive a decrease in propellant quantity at the time. Releasing the TEST switch to center will lock the displays to the readings that they had been driven to. TLM would not receive any propellant quantity information at this time. To return to the reading displayed prior to the second TEST 2 (down), the TEST switch is positioned to TEST 1 (up). The crew displays would drive to an increase reading at approximately the same rates. This returns the crew displays close to the reading displayed prior to the second TEST 2 (down). TLM would receive the same information at this time. Releasing the TEST switch to center will lock the displays at the readings they had been driven to. TLM would receive no information at this time.

2.4.2.9.3 Propellant Utilization Valve.

If an unbalance condition exists, which is determined from the INCR, DECR readings on the unbalance meter on MDC-3, the crew may use the propellant utilization valve to return the remaining propellants to a balanced condition. The propellant utilization is not powered until a THRUST-ON command is provided to the propellant utilization gauging control unit (figures 2.4-12 and 2.4-13). The propellant utilization valve housing contains two sliding gate valves within one housing. One of the sliding gate valves is the primary, and the remaining valve is the secondary. Stops are provided within the valve housing for the full increase or decrease positions. There are separate stops for the primary and secondary sliding gate valves. The secondary propellant utilization valve has twice the travel of the primary propellant utilization valve. This is to compensate for the primary propellant utilization valve failure in any position.

The propellant utilization valve controls are located on MDC-3. The OXID FLOW PRIM, SEC switch, selects the primary or secondary propellant utilization valve for operation. The normal position of the OXID FLOW VALVE select switch is PRIM. The OXID FLOW VALVE select switch will not be moved to SEC unless a problem is encountered with the primary valve. The OXID FLOW VALVE INCR, NORM, DECR switch is utilized to position the selected primary or secondary propellant utilization valve. When the OXID FLOW VALVE switch is in NORM and the OXID FLOW VALVE select switch is in PRIM, the sliding gate valves are in a nominal flow position. The upper and lower OXID FLOW VALVE position indicators are gray. When the unbalance meter informs the crew of INCR, the OXID FLOW VALVE switch is positioned to INCR and the OXID FLOW VALVE select switch is in

SERVICE PROPULSION SYSTEM

SYSTEMS DATA

PRIM. The primary sliding gate valve then moves to the increase flow position. The valve movement will take approximately 3.5 seconds to reach the full increase position. The upper OXID FLOW VALVE position indicator would then indicate MAX and the lower indicator would remain gray. The OXID FLOW VALVE would then be left in the INCR oxidizer flow position. This will increase the oxidizer flow approximately 3 percent above the nominal oxidizer flow. When the unbalance meter informs the crew of approximately 0 unbalance, the OXID FLOW VALVE switch is then positioned to NORM. The primary sliding gate valve would then return to the nominal flow position. The valve movement will take approximately 3.5 seconds to reach the nominal flow position. The OXID FLOW VALVE upper indicator would then return to gray. The lower indicator would remain gray.

When the unbalance meter informs the crew to DECR the oxidizer flow, the OXID FLOW VALVE switch is then positioned to DECR with the OXID FLOW VALVE select switch in PRIM. The primary sliding gate valve then moves to the decrease flow position. The valve movement will take approximately 3.5 seconds to reach the decrease flow position. This will decrease the oxidizer flow approximately 3-1/2 percent below that of the nominal oxidizer flow. When the primary gate valve reaches the DECR position, the upper OXID FLOW VALVE position indicator remains gray and the lower indicator would indicate MIN. The OXID FLOW VALVE would then be left in the DECR position. When the unbalance meter informs the crew of approximately 0 unbalance, the OXID FLOW VALVE switch is then positioned to NORM. The primary sliding gate valve would then return to the nominal flow position. The valve movement will take approximately 3.5 seconds to reach the nominal flow position. The OXID FLOW VALVE upper indicator would then return to gray. The lower indicator would remain gray.

The secondary propellant utilization valve is selected by positioning the OXID FLOW VALVE select switch from PRIM to SEC. The SEC position would be selected in the event of a problem with the PRIM. The secondary sliding gate valve would then be controlled and operated by the OXID FLOW VALVE INCR, NORM, DECR switch in the same manner as the primary valve. The position indicators would then operate in the same manner as in the primary, however, now indicating secondary valve position.

The primary and/or secondary sliding gate valves cannot be positioned to block or close off the oxidizer flow completely. This is because the mechanical stops within the sliding gate valves.

SYSTEMS DATA

2.4.2.10 Engine Thrust ON-OFF Control.

Figures 2.4-1 and 2.4-2 illustrate the THRUST ON-OFF logic in the command module computer (CMC), the stabilization control subsystem (SCS) and the manual SPS THRUST DIRECT ON ΔV mode.

The SCS circuit breakers on MDC-8 supply power to selected switches on MDC-7 and MDC-1. The MDC-7 switches distribute a-c and d-c power to the SCS hardware and d-c logic power to selected switches on MDC-1. The G&N (Guidance and Navigation) IMU (Inertial Measurement Unit) circuit breakers on MDC-5 supply power to the G/N power switch on MDC-100. When the G/N power switch is positioned to IMU, power is supplied to the SC CONT switch on MDC-1. When the SC CONT switch is positioned to CMC, a discrete event signal is supplied to the translation control. With the translation control not clockwise (neutral), this allows the discrete event enable to the CMC.

The SPS PILOT VALVE circuit breakers MNA and MNB on MDC-8 supply power to the respective ΔV THRUST NORMAL A and B switches on MDC-1. The ΔV THRUST NORMAL A and B switches on MDC-1 supply arming power to the SPS relays and solenoid control valves. These switches also provide power to the FCSM SPS A and B switches on MDC-1 (for CSM 106 through CSM 111, figure 2.4-1). The FCSM SPS A and B switches are positioned and locked to the RESET/OVERRIDE position (for CSM 106 through CSM 111, figure 2.4-2). The FCSM SPS A and B switches provide enabling power to the THRUST ON-OFF logic (for CSM 106 through CSM 111, figure 2.4-1). The FCSM switch nomenclatures are covered with a blank decal on CSM 106 through CSM 111. The FCSM switches are removed on CSM 112 and subs (figure 2.4-2).

The SPS engine THRUST-ON command is provided by the THRUST ON-OFF logic in the CMC or SCS ΔV modes. The THRUST ON-OFF logic commands the SPS DRIVERS 1 and/or 2. The SPS DRIVERS provide a ground in THRUST ON to the low side of the SPS solenoids and relays. The SPS DRIVERS provide the removal of the ground in THRUST-OFF conditions to the SPS solenoids and relays. DRIVER 1 provides a ground for the SPS solenoids No. 1 and No. 2 and SPS relays S31A3K1 and S31A3K3. DRIVER 2 provides a ground for SPS solenoids No. 3 and No. 4 and SPS relays S31A3K2 and S31A3K4. The SPS relays when energized provide power to the SPS quantity gauging system and SPS He VLV 1 and 2. The SPS He VLV switches on MDC-3 must be in AUTO and the SPS gauging switch on MDC-4 in AC1 or AC2. The solenoid control valves when energized allow GN₂ pressure to be supplied to the respective bipropellant valve (ball valve) actuators. The

SPS

SM2A-03-BLOCK II-(1)
APOLLO OPERATIONS HANDBOOK

SYSTEMS DATA

respective ball valves when opened, allow propellants to flow into the injector and atomize and ignite (hypergolic).

The SPS THRUST DIRECT ON switch on MDC-1 provides an alternate backup mode to the CMC and/or SCS ΔV modes. When the SPS THRUST DIRECT ON switch is positioned to SPS THRUST DIRECT ON, a ground is provided to the low side of the SPS relays and solenoid control valves. The engine is commanded ON (providing the ΔV THRUST NORMAL switches are in A and/or B) regardless of the SPS THRUST ON-OFF logic.

The SPS DRIVERS No. 1 and/or No. 2 will remove the ground on the low side of the SPS relays and solenoid control valves, when commanded by the THRUST-OFF logic in the CMC or SCS ΔV modes. The THRUST-OFF command allows the SPS relays and solenoid control valves to de-energize. This allows the solenoid control valves to dump overboard the GN_2 pressure within the actuator. The actuator spring pressure drives the ball valves closed, thus shutting the engine down.

In the SPS THRUST DIRECT ON mode, the ground on the low side of the SPS relays and solenoid control valves is removed by positioning the SPS THRUST DIRECT ON switch to NORMAL. This allows the solenoid control valves and relays to de-energize and shut the engine down in the same manner as the SPS DRIVERS.

The ΔV THRUST NORMAL A switch positioned to A enables the (A bank) logic circuitry, arms the (A bank) SPS relays and solenoid control valves and energizes injector prevalve A. The injector prevalve then allows GN_2 pressure to solenoid control valves No. 1 and No. 2. The ΔV THRUST NORMAL B switch positioned to B enables the (B bank) logic circuitry, arms the (B bank) SPS relays and solenoid control valves and energizes injector prevalve B. The injector prevalve then allows GN_2 pressure to solenoid control valves No. 3 and No. 4.

The CMC commands THRUST-ON in the CMC ΔV mode by supplying a logic 0 to the THRUST ON-OFF logic. This is providing that the SC CONT switch is in the CMC position and translation control not clockwise (neutral). The SPS DRIVERS then provide the ground to the SPS relays and solenoid control valves. The ΔV THRUST NORMAL A switch is positioned to A for single-bank operation. If double-bank operation is desired, 5 seconds or later after SPS THRUST-ON, the ΔV THRUST NORMAL switch B is positioned to B. When the CMC changes the logic signal from a 0 to a 1, THRUST-OFF is commanded. The ΔV THRUST NORMAL switch A and/or B are then positioned to OFF.

SM2A-03-BLOCK II-(1)
APOLLO OPERATIONS HANDBOOK

SYSTEMS DATA

The SCS ΔV mode is obtained by positioning the SC CONT switch to SCS. A thrust enable signal is obtained from the EMS/ ΔV display counter if at or above 00000.0. THRUST ON is commanded by a +X translation and by depressing the THRUST-ON pushbutton (MDC-1). The +X command signal is necessary to enable the THRUST-ON logic. The +X command function may be obtained by depressing the DIRECT ULLAGE pushbutton on MDC-1, or positioning the translation control to +X, or positioning the translation control counterclockwise (SPS abort mode). The difference between the commands is that the DIRECT ULLAGE or SPS ABORT commands initiate an SMRCS engine direct coil firing and inhibits the SMRCS engine auto (coil) pitch and yaw solenoid drivers, IGNITION 1 (IGN-1). The translation control positioned to +X utilizes the SM RCS engine auto coils; thus, attitude hold may be obtained. The SM RCS engine auto coils (pitch and yaw) are then inhibited automatically 1 second after SPS engine THRUST ON by the IGN-1 command. When the ground to the SPS solenoids and relays are provided by the SPS DRIVER or DRIVERS, the THRUST ON pushbutton may be released and the +X command terminated. The SPS engine firing is maintained by the SCS lock-in circuit. The ΔV THRUST NORMAL A switch is positioned to A for single-bank operation. If double-bank operation is desired, 5 seconds or later after SPS THRUST ON, the ΔV THRUST NORMAL B switch is positioned to B. The +X command function and the THRUST ON pushbutton depressed must be initiated again to supply THRUST-ON to the B bank and B SCS logic. When the EMS/ ΔV counter reads -.1, the EMS/ ΔV counter enable signal is removed and THRUST-OFF is commanded. The ΔV THRUST NORMAL A and/or B switch are then positioned to OFF.

The SPS THRUST ON-OFF logic may be switched from the CMC to the SCS ΔV mode during an SPS engine thrusting period. The translation control may be rotated to the clockwise position or the SC CONT switch to SCS. In either case the THRUST ON-OFF logic is transferred to the SCS ΔV mode. The SPS engine would continue thrusting (providing the EMS/ ΔV counter is at or above 00000.0) by the presence of the SCS lock-in circuit. THRUST OFF will be commanded as in the normal SCS ΔV mode.

If the manual SPS THRUST DIRECT ON mode is desired, the ΔV THRUST NORMAL A switch is positioned to A (for single-bank operation) and the SPS THRUST DIRECT switch is positioned to SPS THRUST DIRECT ON. The SPS THRUST DIRECT ON switch positioned to SPS THRUST DIRECT ON provides a ground to the SPS relays and solenoid control valves. If double-bank of operation is desired, 5 seconds (or later) after SPS thrust ON, the ΔV THRUST NORMAL B switch is positioned to B. To terminate thrust in the SPS THRUST

SPS

SERVICE PROPULSION SYSTEM

SM2A-03-BLOCK II-(1)
APOLLO OPERATIONS HANDBOOK

SYSTEMS DATA

DIRECT ON mode, the SPS THRUST DIRECT ON switch is positioned to NORMAL. Under certain conditions the SPS THRUST DIRECT ON switch positioned to NORMAL will not shut the engine down. The conditions are: with the SCS LOGIC BUS PWR switch on MDC-7 positioned to 2/3, and with the SC CONT switch in MDC-1 in SCS or SC CONT switch in CMC and translation control clockwise and ΔV counter above 0. In the aforementioned condition the SCS ΔV mode has inadvertently paralleled the SPS THRUST DIRECT ON mode. With the SPS THRUST DIRECT ON switch in NORMAL, the EMS/ ΔV counter reaching -.1 would provide THRUST OFF as in the normal SCS ΔV mode. If the SPS THRUST DIRECT ON switch was positioned to NORMAL when the EMS/ ΔV counter was below -.1, the SPS THRUST DIRECT ON switch to NORMAL would shut the engine down.

A manual back-up THRUST OFF command for the CMC, SCS or SPS THRUST DIRECT ON mode is obtained by the ΔV THRUST NORMAL A and B switches. If single-bank operation was used, positioning the applicable ΔV THRUST NORMAL switch to OFF would shut the engine down. If double-bank operation was used, positioning ΔV THRUST NORMAL switches A and B to OFF would shut the engine down. Positioning the ΔV THRUST NORMAL switches A and B to OFF removes the arming power from the SPS relays and solenoid control valves.

The SPS THRUST-ON-OFF logic circuitry also provides several output functions. A ground is provided for the illumination of the THRUST-ON lamp on the EMS display. The ground is sensed by SPS ignition logic. It is noted on figures 2.4-1 and 2.4-2 that as long as the EMS MN A and/or MN B circuit breakers on MDC-8 are closed, with the ΔV THRUST NORMAL switches A and B on MDC-1 in the OFF position and the FCSM SPS A and B switches on MDC-1 positioned and locked in the RESET/OVERRIDE position on CSM 106 through CSM 111 (figure 2.4-1), the SPS THRUST ON light on the EMS MDC-1 will not be illuminated. The FCSM SPS A and B switches are removed on CSM 112 and subs (figure 2.4-2). The SPS THRUST ON light on the EMS will illuminate when a ground is provided through the logic circuit driver No. 1 and/or No. 2, or when the SPS THRUST DIRECT ON switch on MDC-1 is positioned to SPS THRUST DIRECT ON.

The SM RCS auto pitch and yaw RCS disabling signal IGN-1 is not present until one second after SPS ignition in the SCS ΔV mode, and is not removed until one second after SPS THRUST-OFF in the SCS ΔV mode. IGN-2 logic signal is required for the SCS-TVC and MTVC logic. The IGN-2 logic signal is generated at the same time the SPS solenoids are grounded when in the SCS ΔV mode, but is not removed until one second after ground is removed to maintain SC control during SPS thrust-off decay.

SERVICE PROPULSION SYSTEM

SM2A-03-BLOCK II-(1)
APOLLO OPERATIONS HANDBOOK

SYSTEMS DATA

The SPS ROUGH ECO caution and warning light on MDC-2 for CSM 106 through CSM 111 is covered with a blank decal. The flight combustion stability monitor system is rendered inoperative on CSM 106 through CSM 111 by stowing the power input wires to the FCSM, figure 2.4-1. The FCSM SPS A and SPS B switch nomenclatures are covered by a blank decal on CSM 106 through CSM 111. The FCSM SPS A and SPS B switches are positioned and guarded to the RESET/OVERRIDE position on CSM 106 through CSM 111 (figure 2.4-1). The SPS ROUGH ECO caution and warning light, the FCSM SPS A and SPS B switches, the SPS READY signal to the CMC and the FCSM components are physically removed on CSM 112 and subs (figure 2.4-2).

2.4.3 PERFORMANCE AND DESIGN DATA.

2.4.3.1 Design Data.

The following list contains specific data on the components in the SPS:

Helium Tanks (2)	3600±50-psia nominal fill pressure, 4400-maximum operating pressure. Capacity 19.4 cubic ft each, inside diameter 40 in., and a wall thickness of 0.46 in. Weight 393 lbs. each.
Regulator Units (2)	Working regulator, primary 186±4 psig, secondary 191±4 psig. Primary lockup 195 psig. Secondary lockup 200 psig. Inlet filter 10 microns nominal, 25 microns absolute. Normally locked-up (closed) regulators, primary 181±4 psig, secondary 191±4 psig. Primary lockup 195 psig. Secondary lockup 205 psig.
Check Valves - Filters	Inlet port 40-micron nominal, 74-micron absolute. Test ports 50-micron nominal and 74-micron absolute. One at inlet to check valve assembly; one at each test port.
Pressure Transducers (2)	Fuel and oxidizer underpressure setting (SPS PRESS light, MDC-2), 157 psia. Fuel and oxidizer overpressure setting (SPS PRESS light MDC-2), 200 psia.
Propellant Utilization Valve Control (2)	Increase position, approximately 3% more than nominal flow. Normal position, nominal flow. Decrease position, approximately 3.5% less than the nominal flow. Response time, normal to increase or vice versa, or normal to decrease or vice versa, is 3.5 seconds.

SERVICE PROPULSION SYSTEM

SM2A-03-BLOCK II-(1)
APOLLO OPERATIONS HANDBOOK

SYSTEMS DATA

Quantity Sensing System Accuracy	Indicators - Difference between actual quantity and total indicated quantity for each propellant shall not exceed $\pm 0.35\%$ of full tank plus $+0.35\%$ of propellant remaining separately to total fuel and oxidizer separately. TLM - Difference between actual quantity in each tank and that represented to TLM be within $\pm 0.35\%$ of full tank plus $+0.35\%$ of propellant remaining.
Helium Relief Valve (2)	Diaphragm rupture, 219 ± 6 psig. Filter, 10 microns nominal, 25 microns absolute. Relief valve relieves at 212 minimum to 225 psig maximum, reseats at 208 psig minimum. Flow capacity 3 lbs/minute maximum at 60° F and 225 psig. Bleed device closes when increasing pressure reaches no greater than 150 psig in cavity, and reopens when decreasing pressure has reached no less than 20 psig.
Oxidizer Storage Tank #1	Total tank capacity 11284.69 lbs. Fill pressure 110 psia. Height 154.47 in. Inside diameter 45 in., wall thickness 0.054 in. 128.52 cubic feet
Oxidizer Sump Tank #2	Total tank capacity 13923.72 lbs = 57.0%. Fill pressure 110 psia. Height 153.8 in., diameter 51 in., wall thickness 0.054 in. 161.48 cubic feet
Fuel Storage Tank #1	Total tank capacity 7058.36 lbs. Fill pressure 110 psia. Height 154.47 in., diameter 45 in., wall thickness 0.054 in. 128.52 cubic feet
Fuel Sump Tank #2	Total tank capacity 8708.10 lbs. = 57.0%. Fill pressure 110 psia. Height 153.8 in., diameter 51 in., wall thickness 0.054 in. 161.48 cubic feet
Total Propellant (In Tanks)	Total oxidizer 25208.41 lbs = 103.4%. Total fuel 15766.46 lbs = 103.4%. 99.9% oxidizer gaugeable 24389.10 lbs. 99.9% fuel gaugeable 15252.70 lbs.

SERVICE PROPULSION SYSTEM

SM2A-03-BLOCK II-(1)
APOLLO OPERATIONS HANDBOOK

SYSTEMS DATA

All Propellant Tanks	Pressurized to 10±5 psig of helium when empty to prevent collapsing of tanks (negative pressure of 0.5 psig will collapse tanks).
Interface Flange Filter (2)	500 microns absolute.
GN ₂ Bipropellant Valve Control Systems (2)	GN ₂ storage vessel pressure 2500±50 psi at 68°F, 2900 psi at 130°F. Support 43 valve actuations. 120-cubic inch capacity, each. Inside diameter 4.65 in., length 9.6 in. Regulator - single stage, dynamic 187 psig minimum. Lockup pressure 195 to 225 psig. Relief valve relieves at 350±15 psi, reseats, at not less than 250 psi. *GN ₂ filters, one between each GN ₂ supply tank and injector pre valve, 5 microns nominal and 18 microns absolute. One at each GN ₂ regulator outlet test port, 5 microns nominal and 18 microns absolute.
Engine (1)	750-second service life. Support 36 restarts minimum. Expansion ratio = 6 to 1 at ablative chamber exit area = 62.5 to 1 at nozzle extension exit area. Chamber cooling, ablation and film cooled. Nozzle extension, radiation cooled. Injector type, baffled, unlike impingement. Oxidizer lead 8 degrees Length 159.944 in. maximum Nozzle extension exit diameter 98.4 in. inside diameter Weight approximately 650 lbs. Injector flange temperature, illuminates SPS FLANGE TEMP HI caution and warning light on MDC-2 at 480°F. (Light disconnected and covered with decal on CSM 108 and subs.) SPS Pc transducer, Pc displayed on MDC-1 through SPS Pc α switch to SPS Pc α indicator on MDC-1. Green range on indicator is 65 to 125% (psia). Normal 95 to 105% (psia).

*CSM 108 and subs.

SERVICE PROPULSION SYSTEM

SM2A-03-BLOCK II-(1)
APOLLO OPERATIONS HANDBOOK

SYSTEMS DATA

Heaters (6)	6 heaters, 2 elements on each heater, 3 elements in series on the fuel side rated at 15 watts, 9.4 watts, and 18.8 watts; 3 elements in series on the oxidizer side rated at 15 watts, 9.4 watts, and 18.8 watts. SPS heater switch position A/B on MDC-3 supplies 28 vdc to 12 elements. SPS heater switch position A on MDC-3 supplies 28 vdc to 6 elements.
Gimbal Actuators	Structural mounting pad offset 4 deg to +Y. About Z-Z axis ± 4.5 (+0.5, -0.0) deg with additional 1 deg for snubbing (yaw), null 1 deg to +Y (thrust vector) during SPS thrusting periods, 0 degree during non SPS thrusting periods. About Y-Y axis ± 4.5 (+0.5, -0.0) deg with additional 1 deg for snubbing (pitch), null 2 deg to +Z (thrust vector) during SPS thrusting periods, +1.5 to +Z during non SPS thrusting periods.
Overcurrent Relays (4)	Overcurrent dependent upon temperature during start transient and steady state. Quiescent current of 60 milliamps ± 10 percent. Pressurized to 3 to 5 psi of dry air. Deflection rate 0.12 radians per second (low side, 6.87° per second) to 0.132 radians per second (high side, 7.56° per second).

2.4.3.2 Performance Data.

Refer to CSM/LM Spacecraft Operational Data Book SNA-8-D-027 CSM (SD 68-447).

2.4.3.3 SPS Electrical Power Distribution.

See figures 2.4-17 and 2.4-18 for electrical power distribution.

2.4.4 OPERATIONAL LIMITATIONS AND RESTRICTIONS.

a. Propellant quantity gauging subsystem is operational only during engine thrusting periods. A 4 ± 1 -second SPS thrusting period is required before the primary capacitance system provides updated information to telemetry and crew displays with the PUG MODE switch in PRIM or NORM. In addition, with the PUG mode switch in PRIM, NORM, or AUX position, the crew display readouts and unbalance meter should not be considered accurate until the SPS engine is thrusting for at least 25 seconds. The delays plus the previous statement are to allow the propellant to settle and stabilize within the SPS tanks before the gauging system is within its accuracy.

b. Pitch and yaw gimbal actuator limitations:

1. Allow one-half second between actuation of the GMBL MOTOR switches on MDC-1 to minimize power transients.

SYSTEMS DATA

2. The secondary gimbal motors should be in operation in the pitch and yaw gimbal actuator for any SPS engine firing for back-up modes of operation.

3. The TVC SERVO PWR switch 1 on MDC-7 should not be positioned to AC1/MNA and TVC SERVO PWR switch 2 on MDC-7 positioned to AC2/MNB or switch 1 to AC2/MNB and switch 2 to AC1/MNA in excess of one hour prior to an SPS engine firing. This would result in some preheating of the pitch and yaw gimbal actuator clutches which could result in a degradation of actuator clutch performance.

4. Do not operate the pitch and yaw gimbal actuator motors without applying power to the thrust vector control servo amplifiers as the pitch and yaw gimbal actuators have a natural tendency to extend or retrace (depending on altitude and pressure) and may drive the SPS engine from snub to snub resulting in vehicle motion.

5. The pitch and yaw gimbal actuator operating time should be held to a minimum. The pitch and yaw gimbal actuator clutches with gimbal motors operating are capable of holding the SPS engine at a given position during the boost phase of the mission (820 seconds) followed by a 100-second SPS engine abort firing without degradation. If no SPS abort firing is required the gimbal motors are shut down at earth orbit acquisition. The gimbal motors are placed into operation 1 minute prior to S-IVB translunar injection with clutches holding the SPS engine at a given position, followed by a 5-1/2-minute S-IVB firing (translunar injection), followed with CSM separation from the S-IVB, followed by a 614-second SPS engine firing, and followed by a 1-minute idle post fire before gimbal motors are turned off and the clutches not degraded.

c. Engine design minimum impulse control limit is 0.4 second; however, mission minimum impulse may be longer.

d. For other operational limitations and restrictions, refer to Volume 2 of the AOH SPS malfunction procedures.

SPS

SM2A-03-BLOCK II-(1)
 APOLLO OPERATIONS HANDBOOK

SYSTEMS DATA

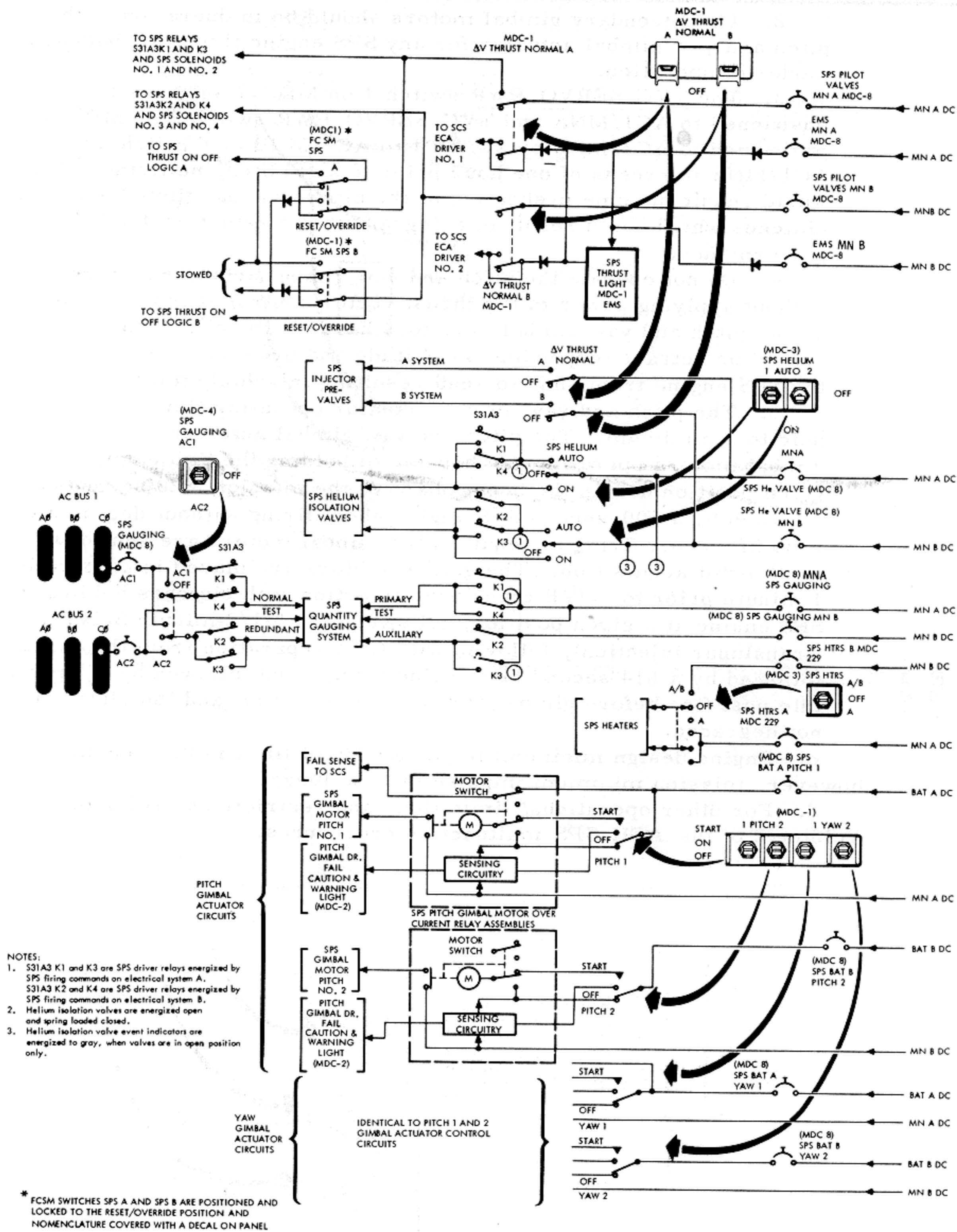

SM-2A-1563F

Figure 2.4-17. Electrical Power Distribution (CSM 106 Through CSM 111)

SERVICE PROPULSION SYSTEM

SM2A-03-BLOCK II-(1)
 APOLLO OPERATIONS HANDBOOK

SYSTEMS DATA

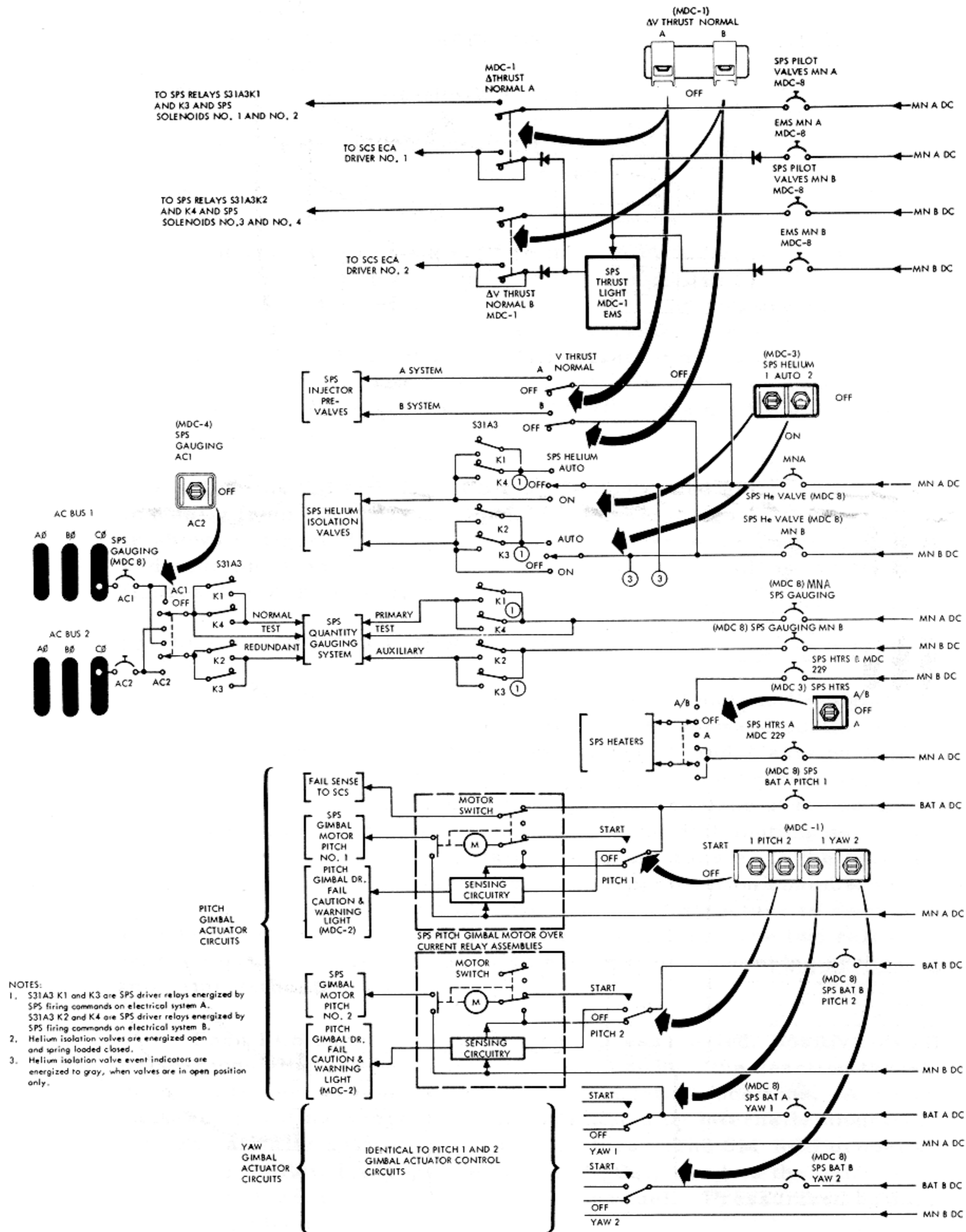

SPS

Figure 2.4-18. Electrical Power Distribution (CSM 112 and Subs)

SM-2A-2029A

SERVICE PROPULSION SYSTEM