

TRICK OR TREAT

'We've got a cosmic
Watergate, almost.'

UFOs Return

**Trick
or Treat?**



C. HAAS

ANOMALY

Published irregularly by:
Specialized Research
Box 351, Murray Hill Sta.
New York, N.Y. 10016

Not sold by subscription.
Send a stamped (20¢) self-
addressed manila envelope
for the next issue. Do not
use air mail stamps. In-
clude your zip code.

Vol. II-No. 1-Issue #11

APRIL 1974

• Eugene Trowbridge of Newark, N.J., was blown off his toilet when a city sewer crew turned on a high-pressure sewer-cleaning hose in the main outside his house.

"I heard an awful noise, like a tornado, the awfulest noise I ever heard, then boom, the thing erupted," said Trowbridge. "It just blew its stack, it blew me right off. I almost fainted."

He said the sudden explosion shocked him for a few minutes, until he realized what happened. He called in the sewer cleaning crews, but, according to Mr. Trowbridge, "They just stood there and laughed. They thought it was a joke."

"I called up the main office and they had the nerve to laugh at me, too. I said, 'Don't laugh at me, buddy boy,'" Mr. Trowbridge reported.

The explosion was caused by a clogged vent in the Trowbridge house at 804 Church Street. Nathan Olmstead, Newark Public Works superintendent, said clogged vents could be a health hazard. "If in fact it did blow out a toilet, we would only be doing someone a favor by going in and making them comply with regulations," he explained.

Mr. Trowbridge intends to sue if he is not given adequate warning of any future sewer-cleaning operations.

"They better tell me the next time they're cleaning," he warned. He said he had a voucher for filing a claim against the city but wouldn't fill it out this time because he "gave them hell" over the telephone. *Rochester Democrat and Chronicle* (B. Eakins)



Several Ham radio operators and experimenters claimed to contact extraterrestrial intelligences in the 1950's. George Hunt Williamson's book The Saucers Speak discussed many of these experiments. Others busily taped the voices of alleged space entities at seances (remember Monka?). Then Philip Rodgers, a blind musician in England, made an incredible discovery. He found he was able to record unseen presences on an ordinary tape recorder. Voices professing to belong to space people.

Today this same kind of recording is being taken very seriously by parapsychologists, some of whom think they are recording the voices of the dead. Philip Rodgers' earlier tests have, in a sense, now been verified by Dr. Konstantin Raudive and many others. Of course, these voices do not come from the dead any more than they came from outer space in the 1950's. These are really just new manifestations of the VLF radiations that have been puzzling radio operators since World War I.

Nevertheless, Philip Rodgers made a very important contribution to the UFO lore and his experiments were a valuable breakthrough.

Mr. Rodgers died on October 8, 1973. His many American friends will miss him.

Cattle Mutilations

PHANTOM HELICOPTERS

The great UFO wave of 1973 began in the northeast in February and was marked by the reintroduction of phantom helicopters; large unmarked machines whose configurations and sounds are unmistakable. As usual, when witnesses like Evan C. Williams, mayor of Milton, Pa., reported seeing one of the choppers a thorough check of all airports and military installations drew a blank.

By midsummer, however, the phantom helicopters were being associated with the widespread cattle rustling in the midwest. Huge military-type helicopters were seen hovering low over cattle herds in several states. Farmers were even taking potshots at them. (See report from Mo., ANOMALY #10, p. 196.) The whirlybirds were operating at night without lights in rural areas.

"We were near Jones' place southeast of town, came around a curve and up over a hill," Rev. Albert Lambeth of Mark, Iowa said in April. "Then this helicopter started to raise out of the field right in front of us. It hovered over our heads a few seconds, and when we got out of the car, we could see the tail structure and the fuselage structure. It wasn't one of those bubble-type copters. It had an enclosed fuselage that I would guess could carry four or five men. And there were no visible numbers on the helicopter."

Local law officials, the FAA and FBI all failed to pinpoint the origin of these choppers although they were apparently the size of military ambulance copters and would have required a lot of fuel and logistical support.

We had gone through it all before. We had pursued phantom helicopters up and down the East coast in 1966-67, and cited a number of these cases in our books and articles.

In October, at the height of the U.S. UFO flap, a curious UPI report appeared describing two "mystery helicopters" seen near Saigon.

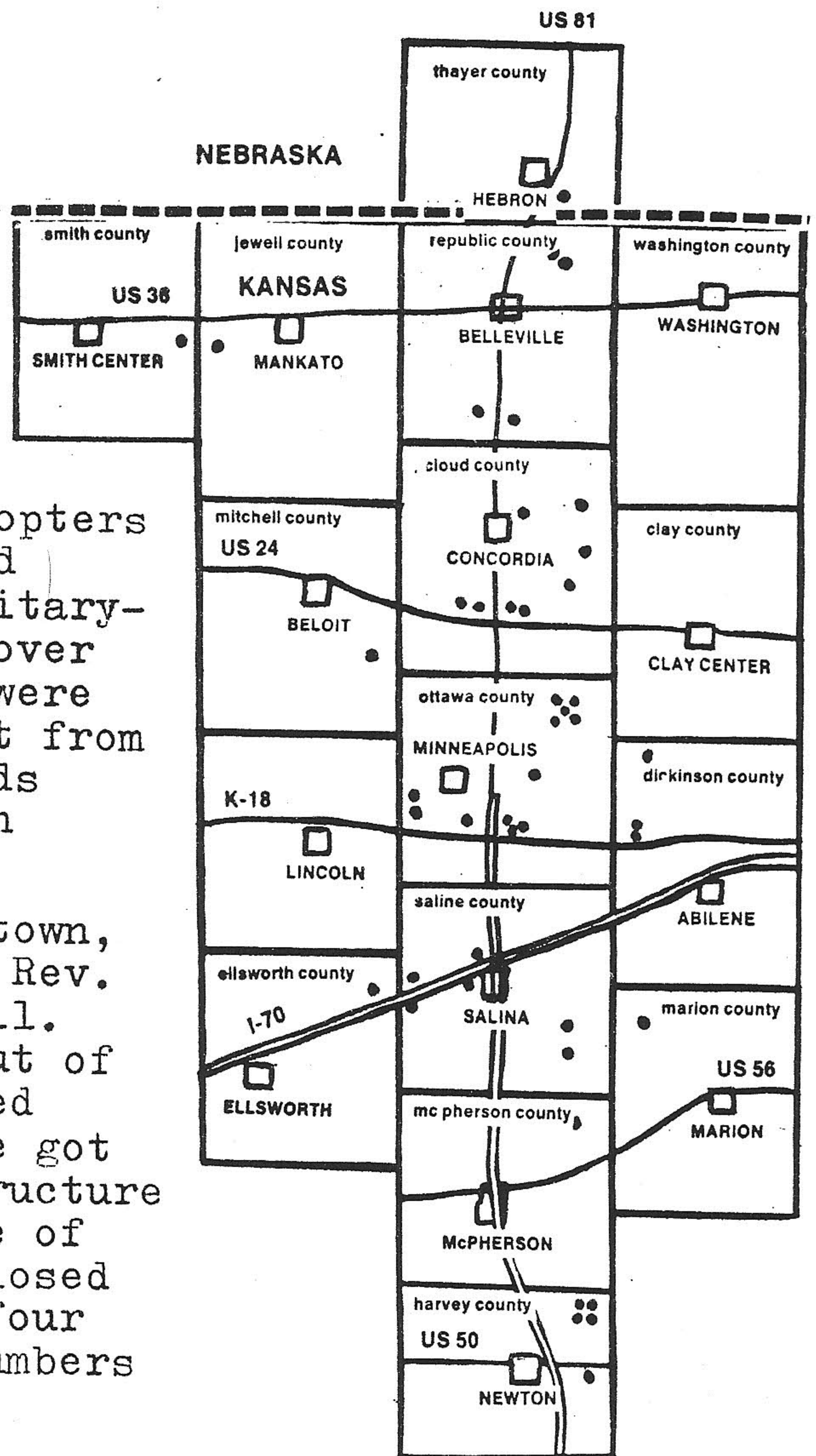

Death Pattern

Dots here indicate where individual cattle were found recently, many bearing possible knife wounds on the carcasses. The deaths are on either side of U.S. 81.

CATTLE RUSTLING FOR BEGINNERS

An estimated \$30,000,000 worth of cattle are rustled in the U.S. annually. Modern cattle rustlers are very professional and very efficient. They drive their trucks into a field, slaughter several choice cows and butcher them on the spot, loading only the prime cuts into their vehicles. They leave hides, forequarters, etc. behind, along with plenty of foot and tire tracks. It is questionable if several different teams in different states could suddenly acquire expensive helicopters. Our phantom helicopters were turning up everywhere at once this summer.

As in previous UFO waves, somebody or some thing was wantonly slaughtering cattle, sheep and dogs across the country throughout 1973. Unlike mundane cattle rustlers, these phantom animal mutilators did not leave any tracks or clues behind, even in mud and snow. The animals were killed with surgical precision, just as in the many cases described in our books. Most perplexing of all, there was never any blood in evidence. Real cattle rustlers leave plenty of blood behind.

Jerome Clark of Minnesota, Loren Coleman of Illinois, and a few other researchers investigated mutilations in their areas. But the phenomenon spread from Calif. to New York. Some lawmen speculated they were dealing with a devil-worshipping cult. But we have seen the results of sacrificial rites in cemeteries and on beaches and the sacrificed animals were always slaughtered crudely, clumsily, bloodily, and were left surrounded by spent candles and other debris. (See report on page 215)

The accompanying story from Kansas tells how the destroyed animals had one ear and/or their tail cut off. In some cases their sex organs were also mutilated. In Minn., Clark examined animals with this same puzzling "trademark".

This mystery is not confined to the U.S. In 1972 there were at least six similar cases in Sweden. (See SPECIAL REPORT #3, an English bulletin issued by UFO-SWEDEN; Brinkgatan 7; 591 00 MOTALA, Sweden. Send one dollar's worth of International Postal coupons and they will send you three issues.)

Cont'd on page 209

THE KANSAS CITY TIMES Saturday, December 22, 1973

★ Deaths Puzzle Farmers

By Richard D. Ralls
A Member of the Staff

Concordia, Kan.—A dead heifer's ear had been sliced or chewed to the skull. A bull was found with a pound of meat removed from a front quarter. Another had no tongue or nose and again was missing an ear.

Ordinarily such occurrences in cattle herds would be shrugged off as the work of predators, cleansing the prairie of all but the skeleton of diseased animals.

But recent cattle deaths near here have fallen into an eerie pattern. Of the many breeds feeding on the Kansas grasslands, almost all the deaths have been black cows, mostly Angus. They have died within a few miles of U.S. 81 in a dozen counties in north-central Kansas. Even more bizarre, many bore knife marks on the carcasses, including the apparent butchering of the sex organs from both bulls and heifers.

What has appeared to be the mutilation of more than 40 cattle has dumbfounded investigating sheriff's posses, highway patrol troopers and Kansas Bureau of Investigation agents. Although they and local farmers scatter blame among possible sex deviates, hippies or members of a religious cult, they shake their heads admitting: "We just don't know who is behind this."

Disease and death are not uncommon among cattle in the winter months, especially in calves. But even farmers who have witnessed many winters have been shaken by the strange mutilations in their pastures.

While sheriffs and farmers are baffled by the situation, some state officials have blamed disease for many of the cattle deaths. Subsequent feeding by predators has removed the softer parts of the carcasses such as the nose and ear, they said.

Yet they have not been able to account for the knife wounds, which were identified in autopsies.

Claire Robinson, president of the Kansas Livestock Association, said the number of cattle deaths involved would not be ab-

DEATHS on Next Page



C.1967- Dell Pub. Co.



John Keel seems a shadow of his old self without the beard. Notice the "Keel for King" button on his jacket.

C.1973- CAVEAT EMPTOR

Here in response to untold thousands of requests are actual photos of the strangest oddity of all...an android constructed on some dark and distant planet. Note the high intellectual forehead, firm jaw and third eye. Eat your heart out, Paul Newman.

Puzzling Deaths

Continued

normal in cold weather if the animals died from natural causes.

"I really believe someone is responsible," Robinson said. "It sounds like a prank or something."

"We talked about this in Topeka last week. It's so unbelievable that this would happen . . ."

A 500-pound heifer owned by state Sen. Ross Doyen of Concordia was found Thursday morning two miles east of Concordia, lying behind a grain bin on land he farms about 100 yards from a blacktop roadway. Part of its left ear was missing and a 6-inch hole had been gouged in its belly.

At first investigators believed the ear and hole were cut with a knife and they were ready to add Doyen's Angus to the mystery. But an autopsy performed at the veterinarian diagnostic laboratory at Kansas State University indicated the heifer died of acute bloating of the stom-

ach. The hole and ear marks apparently were made by coyotes, officials said.

Doyle Heft, state brand commissioner, said the so-called cattle sex maniac probably is only a combination of shipping fever disease and the picking of carcasses by coyotes, crows and other carrion-eating creatures.

"Ninety-nine per cent of the deaths in which sex organs have been removed from cattle in north-central Kansas occurred from natural causes," Heft said.

His statement outraged law officers and farmers along U.S. 81 who are convinced someone or something has been butchering their cattle without reason.

"These heifers are so tame it wouldn't be any trouble to walk up to them," Doyen, a Republican legislator from the 23rd District, said. "If that ear hadn't appeared cut, I wouldn't have thought anything about it. Whoever's cutting on them always cuts an ear off, that's their trademark."

Doyen echoed the thoughts of

many farmers, some fearful their lives may be threatened. "It's hard to imagine more than one person being that sick," he said. "But we've got an awful lot of weird people in this country."

Authorities said they do not know whether the cattle were dead before any butchering took place. But many think they were killed and butchered at the same time.

"I'm really not going to be surprised if it isn't some cult type of thing," Galen Morford, Harvey County sheriff, said. "When they let witches practice over at the state industrial reformatory at Hutchinson there's no telling what will happen."

Two other points confounding investigators have been the absence of blood and footprints. Even on warm days, with the carcass freshly killed, there has been no bleeding on or around the animal. Some believe the cattle were drained of blood.

No human tracks have been detected near each mutilation,

even in fresh snow.

"We worked on this thing trying to come up with some kind of pattern but just aren't coming up with a thing," C.P. McGuire, Cloud County undersheriff, said.

"We had one that was basically in a mudhole, maybe 20 feet by 75 or 100 feet," McGuire said. "When they called and told us it was in a mudhole, we were gung ho, thought sure we'd have footprints."

He shook his head. "You can understand why we're up against a stump."

"We've now lost eight in Cloud County," McGuire said. "The ones found up toward the Nebraska line were killed in October and appeared to have been butchered for the meat."

McGuire said more recent kills south of U.S. 24 to Newton, Kan., generally had only their sex organs and parts near the head and neck removed.

"They take the eyeballs, the tongue, snouts or maybe a swish of the tail," Deputy Sam Budreau said. "But 27 had

See KANSAS on Page 208

The Legend Of 'Hitchhiking Jesus' Gains Momentum On N.Y. Freeway

by CYRIL O'CONNOR

If you have ever picked up a hitchhiker who just vanished without a trace from your car before you stopped, you've got lots of company.

For legends of vanishing hitchhikers have been drifting in and out of American folklore for decades. The latest 'urban legend' concerns a man resembling Jesus who prowls the upstate New York Freeway.

Lydia Fish, a folklorist at State University College in Buffalo, N.Y., has compiled a report called 'Jesus on the Thruway: The Vanishing Hitchhiker Strikes Again'.

In some versions of the story that she has heard, the motorists seemed to think the hitchhiker was Christ and he warned the drivers that the "day of judgment was near."

"In the stories I've heard, he always sat in the back seat and always put on the seat belt," said Miss Fish. "When the people noticed he was gone, the seat belt

was still buckled."

Miss Fish said the story "almost always is told as being a true story that happened to somebody else, you never are able to find the person it really happened to."

In many versions of the story, the hitchhiker is described as "a beautiful young hippie" in "shining white" clothes or jeans who resembles Jesus or an angel, said Miss Fish.

Miss Fish recalled a class discussion in which a student told of a couple driving along the thruway who picked up the hippie in shining white clothes.

After he vanished from the car, the people told a toll collector on the thruway that they had lost a hitchhiker.

"He told them not to worry," said Miss Fish. "At least a dozen cars had come through the gate that day with the same story."

Miss Fish said many of her students firmly believe the story.

★ Kansas Cattle Deaths

Continued

their sex organs removed, predominantly the heifers. Some had their external organs taken, some had their complete reproductive areas removed.

"There was no blood loss in any of them, and some were still warm enough," he added.

Budreau said within the last three weeks the problem has shifted northward again after following a path south down U.S. 81.

"We've had nearly 12 in the area this month," Budreau said. "The kills have increased since the ice storm two weeks ago. They were every three days, then every other day, and until last week, every day."

McGuire said one of the early theories assumed the front quarters were taken for coyote bait until the removal of sex organs. "That just doesn't make any sense at all."

McGuire said most of the cattle were found in secluded areas, such as a draw or ravine. But some were lying as close as the barn behind a farmer's house.

Most of those dead were

young calves valued at \$200 to \$300 each. A prized bull, valued at \$3,000, was among those found, the farmer said. No value was placed on the potential price of the animals at the slaughterhouse.

A \$500 reward is being offered by the Kansas Farm Bureau for information on the mutilations.

Farmers have agreed to chip in and make the reward more attractive, McGuire said.

The mystery has swamped law officials in each county affected, consuming time usually spent handling traffic violations and one or two burglaries before Christmas, McGuire added.

"We've only got three men to patrol the whole county, plus the highway patrol," Budreau said. "We've worked 20-hour days, increasing the patrols over every back road. I've been stuck so many times . . ."

"Another thing, they do such a clean job," Budreau noted. "They clean the bones, no bleeding, and take the ear at the base of the skull." Pointing to snapshots of some victims, Budreau said: "When they cut the eye out they've taken the membranes and eyelids and all."

Another aspect puzzling investigators has been the absence of a death mark on the cattle. No facial stab or gunshot

wounds have turned up on the cows, McGuire said, nor has there been a blow to the head.

Nine cattle have been sent to Dr. Harry Anthony, director of the K.S.U. veterinarian lab, for autopsies.

Anthony said four of those examined apparently had died from a cattle disease known as blackleg. The sickness attacks a heavy muscle, usually a hind leg, and forms a toxic gas which enters the bloodstream and kills the animal.

Two others, including Doyen's heifer, died from acute bloat, he said. The cause of death of another could not be determined because of deterioration.

The cause of death of the remaining two, both with apparent knife wounds in the ear and other parts, will not be known until more lab work is completed checking for drugs.

Ottawa County, in the center of the problem area, has recorded the most deaths. A dozen cattle have been found missing an ear or their sex organs or both.

One cow in Ottawa County had been shot in the eye with a high-powered rifle, a sheriff's department spokesman said. Some larger cattle, including a 1,500 pound Angus bull, have been lost there. Some have been

found in pairs, killed the same night.

"There's no indication of blood or bleeding at any of the sites," Gary Dir, a 27-year-old deputy sheriff there, said. "Even with the whole back end cut out, there's no indication of the bleeding that should be there. I've spent all my life except the last eight months on a farm and I know when a critter's been cut."

Almond Baker, a farmer in rural Minneapolis, Kan., said he lost two cattle "not a quarter mile from my house and I was home."

His neighbor, Emory Eklund, lost a cow the same week as Baker. Another neighbor, Mrs. Genevieve Reed, lost a white-faced heifer and a black bull two weeks ago.

"They didn't have time to take the sex organs out of the heifer," Mrs. Heed said. "Some gals were calling their dogs and walking nearby. That must have scared them off."

She said two persons may be involved because of a report of boot tracks near one of the kills. Cowboy boot tracks and insulated boot tracks were spotted around her bull.

BERRY, Ala. (AP) — A mysterious illness that afflicted more than 80 pupils and teachers at an elementary school in this Northwest Alabama town has been diagnosed as a case of mass hysteria.

That was the conclusion reached by a state health officer yesterday after a two-week in-

vestigation of the incident. A psychiatrist who has lived among the residents most of her life agreed the illness was imagined and not real.

Dr. Inez Fowler, the psychiatrist, said those who had the illness, characterized by an itching rash, dizziness and nausea, were not actually sick — they just thought they were.

The rash first appeared May 11; and before the day ended, 79 pupils and three teachers were treated at a local hospital and released.

80 persons take sick at once

Sunday, December 30, 1973

Mass illness in theater a mystery

Gillespie, (AP)
Authorities remained puzzled Saturday over why more than 80 persons suddenly became ill during a feature film showing at a movie theater in Southern Illinois.

Eighty-four persons, most of them teen-agers, were taken to hospitals Friday night complaining of nausea, headache and dizziness. Eight persons

were admitted and were reported in good condition Saturday.

Gillespie is about 50 miles northeast of St. Louis. It has a population of about 3,000.

Dr. Lee Johnson, trauma surgeon at St. Francis Hospital in nearby Litchfield where 76 persons were taken, said he didn't rule out the possibility of "mass hysteria," but was

awaiting the results of medical tests.

Sheriff Richard Zarr of Macoupin County, however, said he felt differently.

"It wasn't any kind of follow-the-leader type of thing. Seven or eight people were lying on the sidewalk in front of the show. These people were actually passed out. We were reviving them with oxygen and

everything else," he said.

Zarr said those inside the theater suddenly and without explanation began feeling ill during a showing of the film, "Paper Moon." They left the theater and many began collapsing on the sidewalk.

Authorities were investigating the possibility that a foreign substance could have circulated through the theater's ventilating system.

CATTLE MUTILATIONS, Cont'd.

1973 also produced an unusual number of tall, hairy monster sightings. And, as usual, dogs and small domestic animals vanished in the areas where many of these sightings took place. In some cases (i.e., Murphysboro, Ill.) witnesses claimed the creature they saw was carrying a dead dog under its arm! Yet no-one has ever found a half-eaten dog carcass in one of these places, or even the bones. Do our resident monsters even eat the bones?

Fortunately there have not been any verifiable reports of human mutilations in UFO flap areas but there have been several rather mysterious deaths. Some were apparently caused by lightning but others resulted from concussion, distinguishable by bleeding from the nose, mouth and ears. In 1973 there was a sharp increase in cases in which UFO witnesses received mysterious red marks on their neck, on the major nerve just below the ear. Persons suffering such marks usually have absolutely no memory of the period when they acquired it. They simply see a strange light or object approaching their car then- ZAP- the next thing they know they are home in their own bed wondering if it was all just a dream.

The '73 wave followed the basic patterns. As in earlier flaps, the key witnesses were schoolteachers while decoy manifestations such as the now-famous Pascagoula, Miss. case involving two fishermen diverted the press and generated more outerspace propaganda, just as the sheriffs of the midwest went hunting for rustlers and devil cultists. While our astronauts collect rocks, UFOs collect ears?

Relax, Monster Fans, the Nessie Fooled 'Em Again

By **WILLIAM F. WRIGHT**

United Press International

LOCH NESS, Scotland—Great gales of laughter echoed through the wooded glens and out over the copper-green waters of Loch Ness.

On a bluff overlooking the lake, several brawny, kilted highlanders stood convulsed at the sight of a boatload of Japanese poking and prodding the peaty water with an array of expensive electronic equipment.

Two months after launching a much-heralded search for the fabled Loch Ness monster, a team of Japanese investigators had come no closer to solving the mystery than had previous expeditions.

"I have to confess we haven't made much progress," said Konosuke Baba, secretary of the 11-member expedition which arrived in the misty Scottish highlands Sept. 7 to begin a three-month hunt for Nessie, the humped-back monster that many think dwells in the lake.

The Japanese have suffered so many setbacks that some exuberant locals, who once feared that the Oriental visitors would capture

the area's biggest tourist attraction, clap it into an oversize jam jar and take it home, now break into a highland fling at news of each new reversal.

Baba said that at one point, the team's sonar picked up "some mystery object" in the lake's inky-black depths "but we did not have enough experience with the equipment to work out how deep or what size the object was."

Forget the Submarine

He said the team has abandoned plans to bring in a one-man midget submarine from Japan to probe the lower reaches of the lake, believed by some scientists to be 1,000 feet deep in some places. "We came to the conclusion that our submarine was just not suitable for the lake," Baba said. "It is very small and can only dive to depths of 60 meters [197 feet]."

The British firm of Vickers Oceanics, Ltd., turned down the expedition's request for the loan of one of its two-man midget Pisces subs, which can dive to 3,500 feet.

The Japanese say the only creature they have

NOVEMBER 11, 1973

plucked from the 24-mile-long, mile-wide lake is a 6-foot eel, a far cry from the dragon-like beast that many persons claim to have seen and photographed over the years.

But What Can You See?

Baba said the expedition's divers—rubber-suited against the icy water and using oxygen tanks and flippers—have plunged to depths of 134 feet without finding a trace of the monster. "The problem is that, once you get down to 10 meters [33 feet] or so, the water is so dark you can't see much even with our 1,000-kilowatt lamps."

The monster lives, however, on a thousand T-shirts, post cards and other items the canny Scots turn out for the Japanese and other visitors.

The Japanese, who have become almost as much a tourist attraction as the monster itself, work from a fishing boat they rent for \$625 a week. They bristle at the suggestion that they would snatch the monster or do any harm to it.

"It's absolute nonsense," Baba said. "It belongs to Scotland and will remain in Scotland. If we did catch it, we would throw it back."

YETI FILMOGRAPHY

THE ABOMINABLE SNOWMAN OF THE HIMALAYAS (1957) Hammer 85 minutes. Directed by Val Guest. Screenplay by Nigel Kneale. Starring Forrest Tucker, Peter Cushing, Maureen Connell, Richard Wattis, Robert Brown.

HALF HUMAN (1955) DCA/Toho 95 minutes. Directed by Inoshiro Honda. Screenplay by Takeo Murata. Starring John Carradine, Morris Ankrum, Russell Thorson, Akira Takarada, Momoko Kochi, Kenji Sahara.

INVASION OF THE ANIMAL PEOPLE (1962) ADP. Directed & written by Jerry Warren and Virgil Vogel. Starring John Carradine, Barbara Wilson, Robert Burton.

MAN BEAST (1956). Directed by Jerry Warren. Screenplay by B. Arthur Cassidy. Starring Rock Madison, Virginia Maynor, Tom Maruzzi, Lloyd Nelson, George Skaff.

SNOW CREATURE (1953) United Artists 70 minutes. Directed by W. Lee Wilder. Screenplay by Myles Wilder. Starring Paul Langton, Rudolph Anders, William Phipps, Teru Shimada, Darlene Fields.

Sign Him Up!

ROME, Maine (UPI)—A six-foot, 200-pound teenager lifted a 3,000-pound tractor with his bare hands to free a trapped farm worker.

Kennebec County investigator Leo Bazinet said Arthur Hinkley, 18, heard the screams of Lloyd Bachelder, also 18, who was pinned in the seat of the vehicle when it tipped over.

Hinkley somehow lifted the tractor enough for Bachelder to wriggle out. He suffered a fractured hip and internal injuries.

"I don't know how I did it," Hinkley told Bazinet Wednesday, "I can't remember anything."

Boy, 7, Eaten Alive by Giant Ants in Brazil

Agence France-Press

Rio de Janeiro — A 7-year-old boy was attacked and eaten alive in his bed by giant ants near Agrobrazil in the state of Rio de Janeiro, the local press reported Saturday.

The boy, too sick and weak to flee, died within minutes.

The giant ants then attacked four other children in the same family but they were saved when neighbors heard their cries for help. The children's parents were away at the time.

DO-IT-YOURSELF VLF RECEIVER. Since we first wrote about the mysterious signals permeating the very low frequencies we have received many queries about VLF radio receivers. Commercially made receivers are hard to find and are expensive. But if you know electronics you can build one easily by following the specifications below, first published in Radio-TV Experimenter, April-May 1967 (copies of that issue are out of stock so don't bother to write).

VLF reception demands a very long antenna (100 feet or so) away from power lines and other interference. If you live in a city you might as well not bother at all.

Some radio amateurs with VLF equipment claim to have received strange broadcasts allegedly from UFOs during flap periods. But odd voices and weird sounds seem to be common to the band, in addition to normal cosmic noises and sounds created by rocket launchings and nuclear tests. The government uses VLF to communicate with nuclear subs (VLF penetrates water) and the CIA uses it to communicate with spies.

Have fun.

Schematic diagram reveals simplicity of 1-tube VLF receiver.

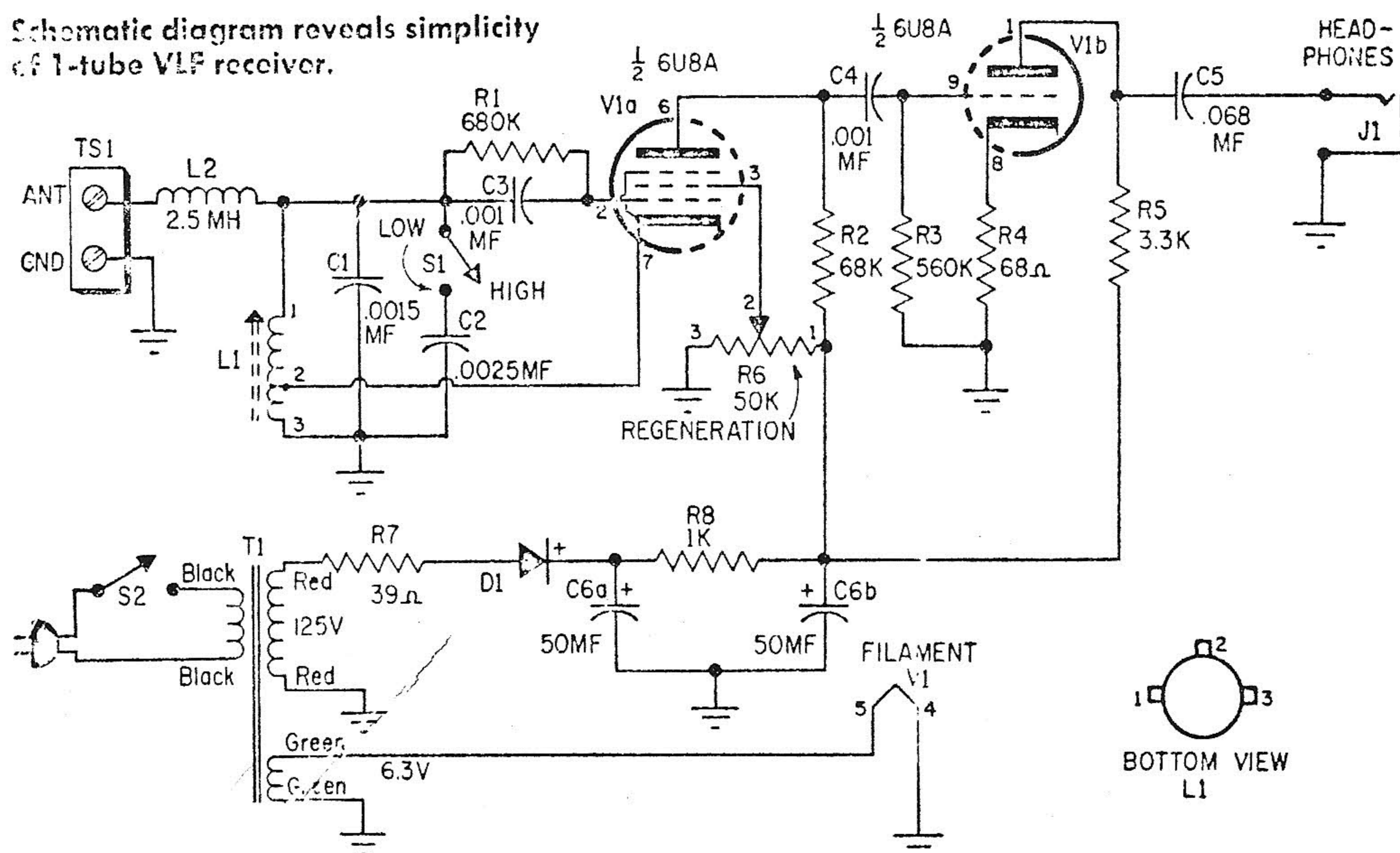

LONG-WAVE RECEIVER PARTS LIST

- | | |
|---|---|
| C1—.0015-mf. silver mica capacitor | R7—39-ohm, 1/2-watt resistor |
| C2—.0025-mf. silver mica capacitor | R8—1000-ohm, 1-watt resistor |
| C3—.001-mf. ceramic disc capacitor | S1, S2—S.p.s.t. slide switch |
| C5—.068-mf., 200-volt tubular capacitor | T1—Power Transformer. Pri.: 117 volt, 60 Hz.; |
| C6—50-, 50-mf., 150-volt dual electrolytic capacitor | Sec.: 125 volt, 50 ma.; 6.3-volt, 2-amp |
| D1—500-ma., 400-piv., silicon diode rectifier (1N2070 or equiv.) | (Knight 54A1411 or equiv.) |
| J1—Open circuit phone jack | TS1—2-screw terminal strip |
| L1—16-42 millihenry TV horizontal-oscillator coil (J. W. Miller 6211 or equiv.) | V1—6U8A tube |
| L2—2.5 mh. RF choke | 2—4-terminal insulated tie strips |
| R1—680,000-ohm, 1/2-watt resistor | 2—Knobs |
| R2—68,000-ohm, 1/2-watt resistor | 1—9x5 1/2 x 1 1/2-inch aluminum chassis |
| R3—560,000-ohm, 1/2-watt resistor | 1—9-prong miniature tube socket |
| R4—68-ohm, 1/2-watt resistor | Misc.—Solder lugs, wire, solder, 6-32 machine screws and nuts, power cord and plug, rubber grommets, etc. |
| R5—3300-ohm, 1-watt resistor | |
| R6—50,000-ohm linear taper potentiometer | |

Estimated cost: \$14.00
Construction time: 3 hours

CHIEF DENIES IT Feb 26, 1973
PHOENIX GAZETTE

Everyone Says He Was Absent

ROYSE CITY, Tex. (UPI) — The city council called an emergency meeting during the weekend to discuss what to do about the town's missing police department — one man and a squad car — when word came that Chief Luther A. Davis was home after an 11-day absence.

Davis would not comment on his whereabouts except to say, "Somebody must have got their wires crossed. I haven't been missing."

The city council of this north central Texas town of 1,535 had issued an all-points bulletin for the chief and his bronzed squad car.

"He just disappeared and didn't even tell the typist where he was going," said city secretary Joe Golden.

Dallas police said the squad car was seen parked in Dallas at one location for several days, but when an officer was sent to get it last Thursday, it was gone.

Davis' wife said she was unable to help city officials. She didn't know where her husband was either.

"There may be a logical explanation for all this, but from where I sit, it would have to be good, and I can't see how it could be logical," Golden said.

Chief 'Lost' 25 Hours

NEWPORT, Vt. (AP) — Control of public statements about the investigation into the 25-hour disappearance during the weekend of Barton's village police chief was officially restricted Monday.

The chief, Roger Plante, 43, was reported to have suffered no serious injuries, according to his attending physician Dr. Terrance Gage.

Dr. Gage said Plante suffered contusions and abrasions of the face and forehead and added "other than being very lame, he's quite all right. He is mentally alert."

But, Orleans County State's Atty. John Howard said "information obtained through the interview with Chief Plante has to date proved futile."

Howard said reported evidence was being examined to better evaluate what happened between late Saturday and late Sunday.

His prepared statement also said, "State's Atty. John Howard has ordered no more information be released by any police officer involved in the investigation."

A massive search for Plante, chief of a two-man police force for the north-eastern Vermont community of about 1,500 persons, began when his cruiser was found abandoned along the side of a road, about a half-mile from the nearest occupied home.

The window in the driver's door was shattered, and police evidence markings indicated two pieces of cloth, a wallet and a boot were found on the road.

However, the interior of the car, other than strewn with shattered glass, showed no signs of disturbance.

Photo brings policeman only trouble

FALKVILLE, Ala. — (UPI) — Jeff Greenshaw, this town's only policeman, took photograph last month of a mysterious, silvery creature walking along a rural road. Now he wishes he hadn't.

The picture, taken at the peak of Unidentified Flying Object (UFO) sightings, brought Greenshaw, 23, publicity. And a lot of trouble.

Shortly after the Oct. 17 incident, Greenshaw said he began receiving threatening telephone calls at home and harassing remarks on patrol. Next his car engine blew up. Then his wife left him and later divorced him, partly because of the picture, he said.

Then the house trailer Greenshaw moved into after his divorce was destroyed by fire. Authorities are investigating the possibility of arson.

Last Friday, city officials asked Greenshaw to resign. They gave no reason.

Greenshaw now is looking for another job in law enforcement. His camera, apparently, has been packed away.

Body burned

Mortuary fire baffles police

HOQUIAM (AP) — The burning of a woman's body in a coffin inside a locked funeral home remains a mystery, Hoquiam Police Chief Richard Barnes says.

Barnes said the body of Mrs. Sam Satlow, 50, was in a coffin in the Coleman Mortuary early on the morning of Dec. 10 when firemen were called by a resident of an upstairs apartment.

Firemen found the body "completely consumed to the hips," Barnes said.

He said, "We have no proof that a crime has been committed, and no evidence of it. It's all conjecture."

Mrs. Satlow had died of carbon monoxide poisoning three days earlier.

Barnes said there is no evidence that would point to

arson, but investigators can't determine the cause.

Barnes has had the burned coffin sent to the Treasury Department's laboratories in Washington, D.C., and expects a report back in about

10 days.

"We really need a logical explanation," Barnes said, "to put an end to so many wild, baseless rumors that are going around the community."

King's Mummy Hunted —

An Egyptian archeologist has traced a secret chamber inside the Great Pyramid of Giza and believes it may contain the mummified body of King Cheops, the newspaper Al Gomhouria said Tuesday. The secret chamber lies about 60 feet below King Cheops' burial chamber, which was found empty when the pyramid was first opened, the newspaper said.

THE OREGONIAN, THURSDAY, DECEMBER 20, 1973

VOLUNTEER FLIGHT OFFICER NETWORK

SATELLITE REENTRY NEWSLETTER

NOCTILUCENT CLOUD REPORTED

The first observation of 'Flight Officer Reports', upon examination, proved to be a report of an unusual event. As these clouds occur infrequently, it is felt that a short discussion describing noctilucent clouds would be in order.

Captain Feldvary, pilot of the Eastern Airlines aircraft, and Mr. W. J. Grote, a mechanical engineer and passenger on the plane, observed the phenomena, compared notes, and agreed upon following details: that the cloud was in view for at least 35 to 40 minutes and appeared quite stationary in relation to the aircraft's motion. They estimated that the object was at a great distance from them and at a height of possibly 50-60 miles above the earth.

Although this phenomena occurs more frequently at higher latitudes than mid-latitudes and more frequently in summer than in winter, it is felt that the object observed was a noctilucent cloud. These clouds, as the name implies, are visible against a background of the night sky while they are illuminated by sunlight. The observer must, of course, be in darkness. Noctilucent clouds can, by the shapes they take, be classified as veils, bands, billows or whirls. The cloud reported by Captain Feldvary and Mr. Grote would be classified as a banded noctilucent.

It is now firmly established that light from noctilucent clouds is scattered sunlight as proven by their spectrum and by the manner in which the cloud disappears when the angle of the depressed sun causes the shadow of the earth to rise above the height of the cloud. These clouds are so tenuous that they cannot be viewed in daylight. For noctilucent clouds to be viewed from the ground, the sky must be free of tropospheric clouds (aircraft, of course, enjoy the benefit of being above most conventional cloud formations) and the angle of the depressed sun must be at least 6° but not more than 16° below the observer's horizon. The geometry of this relationship changes with the season and with the latitude of the observer. The critical facts are: that the observer must be in darkness, the sky dark enough to form a contrasting background for the cloud and that the angle between the sun and the cloud not be so great as to place the cloud in the earth's shadow.

Generally, nocturnal clouds are bluish-white in color but they may take on an orange tint near the observer's horizon. Exposure times for photography of the clouds are mainly governed by the brightness of the sky background and the film being used. For displays of moderate brightness, high speed color film (ASA 160) photography should be attempted using exposures varying between 1/30th second at a solar depression angle of 6° to as much as 30 seconds at a solar depression of 12° at an aperture of F/2.0.

Over the past several years, knowledge of noctilucent clouds has greatly increased but much remains to be done to achieve a better understanding of them. Noctilucent cloud displays are usually quite persistent and last for periods up to and greater than 5 hours, although more tenuous parts may dissipate in a matter of minutes. How they are formed is complex. Some scientists propose that noctilucent clouds are composed of ice coated dust particles, and that the dust particles are, in the main, of extra terrestrial origin.

Noctilucent clouds, even in the latitudes and seasons when they occur, are relatively rare phenomena. Their study is related to many other problems connected with the lowest layer of the ionosphere, the lowest fringe of the auroral layer, and with the influx of cosmic dust. Their continued exploration can contribute greatly to knowledge, not only of this particular level, but of the complete atmospheric and space environment.

Our compliments to Captain Feldvary and to Mr. Grote for the description and for the photograph of this event.

STRATOSPHERIC CLOUD OBSERVATIONS

Dr. John Stanford of the National Center for Atmospheric Research has, as announced in last month's newsletter, written a paper describing his request for observations of stratospheric clouds and how these observations are to be used.

We urgently ask you to be on the alert for these clouds during twilight hours. Your effort is greatly appreciated.

Dr. Stanford's paper follows:

"Dr. John L. Stanford (Physics Department, Iowa State University) is conducting research on the amount of water vapor in the stratosphere. Possible contamination from fleets of aircraft flying at these altitudes could be important if the amount of naturally-occurring stratospheric water vapor is small. However, if large amounts already exist in the undisturbed stratosphere, the effects of man's activities would be correspondingly reduced. The fundamental concern relates to the amount of ozone in the stratosphere which filters the potentially harmful ultra-violet solar radiation. Without this filtering action, the earth could very well be uninhabitable. Instrumental difficulties have resulted in widely varying results from attempts to make measurements directly in the stratosphere. An indirect method, not subject to these same difficulties, is to study the meteorological situations in which stratospheric clouds are reported. Such reports are extremely rare. It would be very helpful to know the true frequency of occurrence of clouds actually lying in the stratosphere.

Airline Flight Officer reports would be especially valuable in this regard, since tropospheric cloud cover would not generally be a major hindrance.

The majority of stratospheric clouds reported by ground observers are of the Mother-of-pearl (nacreous) type. These clouds are usually like leewave clouds, iridescent when viewed favorably with respect to the sun, and occur at altitudes of 17 to 31 km (55,000 to 100,000 ft.), with an average height of about 23 km (80,000 ft.). They are rarely seen, having been reported most often (once or twice a year on the average) over Scandinavia in the winter months. They have also been reported over other parts of Europe, Canada, Alaska, and Antarctica. A few intriguing reports have come from the Southwestern USA. Stratospheric clouds can be distinguished

from another rare form of high cloud, noctilucent clouds, which occur at very great heights of 80 km (260,000 ft.) in the high-latitude summer months.

Other forms of stratospheric clouds have been less frequently reported: cloud veils and high cirrus. In any case, please report your observation to us. The investigators can, from the facts given, distinguish between the different types of stratospheric clouds.

Because of the rarity of stratospheric cloud reports, even one such observation is of importance. Information such as appearance, location, date, and estimated height would be appreciated. Photographs would be especially welcome. Please remember that all stratospheric clouds can only be seen and photographed against a darkening or dark sky as described in the VFON Newsletter of last December 15."

STRATOSPHERIC CLOUD OBSERVED

The first high altitude cloud report resulting from our recent request has been received. The observation was made by a ground based observer, Mr. Russell Eberst, of the Royal Observatory, Edinburgh, Scotland. Mr. Eberst's description follows:

"REPORT OF EXTREME-ALTITUDE CLOUD -- Throughout the night of 2-3 July extreme altitude cloud was visible from Willowbrae (SAO Station No. 0676). The cloud was extremely bright with much fine detail. The descriptions include, "like the sea shore when the tide is out," "like the flesh of a cooked haddock or kipper" and "somewhat akin to cumulus mammatus in parts". The cloud reached up to a maximum elevation of 16° in the north, and the horizontal extent was from NW to NE. The light of stars was little diminished by the clouds. The clouds lasted throughout the night, say, 22:30 UT July 2 to 01:30 UT July 3. The detail changed slowly and much banding and striation was visible."

This report was forwarded to Dr. Stanford, along with his hope and ours that more of these elusive cloud formations will be observed and reported.

Many thanks, Russell, for a fine report.

THE ELECTROMAGNETIC RADIATION SPECTRUM

Frequency in Hertz (cycles per second)

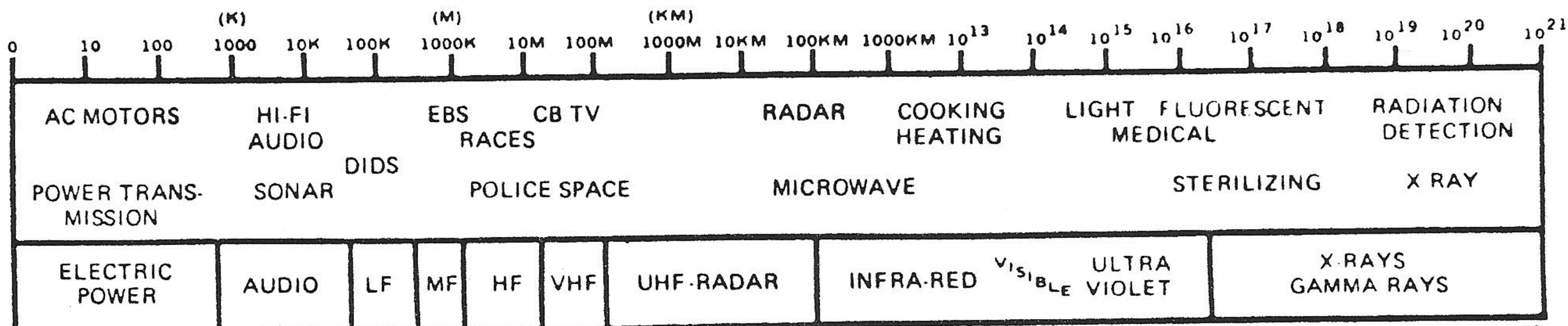

Can be affected by "Electromagnetic Pulse" from nuclear bombs. Range between 0-100k can be affected by Very Low Frequency (VLF) waves.

Thermal radiation, sun's rays, visible UFO manifestations take place in this range.

Nuclear and cosmic radiation. Documented UFO-related injuries caused by energy in this range.

Electromagnetic Fog Seen Peril To Humans

MILWAUKEE, Wis. (UPI) — One of the world's most vital, but least known natural resources is in danger of becoming seriously contaminated, according to an electronics scientist here.

The electromagnetic frequency spectrum, which spans transmission of everything from brain waves to cosmic rays, is being contaminated by electromagnetic interference to such an extent that most cities are virtually blanketed in an electromagnetic fog, according to Dr. Heinz Schlicke, chief electronics scientist of the Allen-Bradley Co.

This contamination of the spectrum, Schlicke said, threatens disruption of automated production lines, weapons and com-

munications systems, computer systems, and medical and other equipment.

Schlicke, recently elected chairman of the electromagnetic compatibility professional group of the Institute of Electrical and Electronics Engineers, said side effects of the contamination may endanger human life.

"The most obvious and generally known problem is interference with aircraft radio communications and navigation, military communications, or mobile radio. This can occur simply through extremely heavy use of frequency bands or because of errant signals from equipment or power lines," Schlicke said.

He said one of the areas under study is the possibility of side ef-

fects of electromagnetic energy on plants, insects, animals and humans.

Everything in nature has a fixed resonance which can be excited by a certain electromagnetic frequency, he said. "At certain frequencies," Schlicke said, "some insects are

killed, and at others the nervous systems of humans are affected."

Schlicke said his group is working primarily to establish built-in electromagnetic compatibility into electrical systems as they are designed.

goat was not actually decapitated — its head had been bent backward and the throat cut.

No one had claimed to have actually seen a voodoo ritual being performed — the voodooers are extremely cautious about detection, according to the park staff—nor has any voodoo practitioner come forward to confess his deed. But the park staff and the police say the circumstantial evidence is overwhelming.

"For a long time I didn't know what it meant," the gardener said. "Then one of the Spanish fellows who works here told me. They come over from the west side and jump around in the dark. There's lots of 'em still make voodoo just like they used to in the islands."

The maintenance men and gardeners say the sacrificed animal is usually found lying in the center of a circle scratched into the earth. The plates and candles are placed at the perimeter, along with melons, oranges, coconuts or other fruit. Coins, usually pennies, are occasionally found under the animal. The chickens are sometimes stuffed with grain.

Voodoo — basically a pantheistic religion — is still widely practiced in Haiti and most other Caribbean islands.

The Haitian Consulate in New York said about 200,000 Haitians presently live in the city. But the consul general, Wilson Florestal, would not speculate on the number who practice voodoo here.

"What others do is none of my business," Florestal said. "Personally, I am a Roman Catholic."

One Catholic priest, who asked not to be identified, said he has always suspected that many Haitians in his Harlem parish continued to practice voodoo.

"Sure, it's heathen, but they believe it," he said. "If these rituals give them hope, if it keeps them going, that's fine. Catholicism has coexisted with voodoo in Haiti for a long time. I guess it can coexist in Harlem just as well."

Det. Herbert Charles of the New York Police Department said there have been no arrests in connection with voodoo worship, although the rituals involve violations of several laws, including littering and the unlicensed slaughter of animals.

"Yeah, we got a lot of voodoo in the park but no one ever catches 'em," Charles said. "They know it's illegal and they're very careful. All we ever find is the remains."

And Central Park officials say they do not plan any immediate action. "I mean, it's not like they're running wild, slinging blood on the tourists," said Sam Samuels, a park spokesman.

"It's a private thing for them and so far they haven't bothered anybody. They're practicing voodoo, all right, but, as far as groups of park users go, you'd have to say they are one of the more discrete."

By ROBERT A. JONES
The Los Angeles Times

NEW YORK — It was the fifth chicken in three weeks. William Robeson knew because he had been keeping count.

This time it was half hidden in the bushes and Robeson peered through the branches. Just like the others, he thought. There, in the middle of Central Park, a white chicken had been placed in the center of a clearing, its stump of a neck oozing blood onto the ground. At the edge of the circle lay three white plates, a candle, some dry corn and several coins.

And for the fifth time in three weeks, William Robeson, maintenance man, started to clean it up.

"DAMN VOODOO," he said.

Voodoo? Does William Robeson mean that? Does he mean that here, next to Fifth Avenue, where elegant people are sharing cocktails on their high-rise balconies, persons are sneaking into the park to slay chickens by candlelight, chanting over their sacrifice to some obscure God? Is that what he means?

There was a pause on the telephone line while Park Director William Pachke considered his answer carefully. "You understand, it's not a serious problem," he said.

"But we do have some, ah, voodoo. Yes. Mostly in the northern section, next to where the Haitian population is concentrated. But it's not serious. It's only a little voodoo. . ."

No one knows exactly how many ritual remains have been found in the park. Robeson and his colleagues in maintenance say the number goes at least into several dozen over a year's time. It's a nuisance, they say, and a waste. All those chickens to be picked up and tossed in the garbage.

It's not always just chickens. A park gardener in the northern section said he recalls the decapitated remains of pigeons, small pigs and, about a year ago, a goat. The

It's No Hoax, Says Archeology Leader, (National Observer, Aug. 16, 1971)

'Skunk Ape' in the Everglades—

A Hairy Giant That Smells Bad

By Dick Bothwell
FROM ST. PETERSBURG, FLA.

"There were five of us camped on top of this big shell mound—three in a large tent, two in a pup tent. About 2:30 a.m. one of the two heard a sound like an elephant walking on this shell mound. The vibrations woke him up.

"He looked out the tent flap and saw what appeared to be a big man, standing about eight feet away in the moonlight. He thought it was one of the party. He lay back down, then heard what sounded like a number of people all talking at once.

"So the two of them in the pup tent got up and woke us up—told what he'd seen. We looked around but saw nothing. But in the morning, we found these huge tracks.

"Footprints just like a man's, three different sizes. The largest 17½ inches long, 11 inches across. I've got plaster casts of it. . ."

Hunting the Monster

That's the way H. C. "Buz" Osbon of Miami, president of Peninsular Archeological Society and board member of the Miami Museum of Science, describes an incident he says occurred last February down in the remote wilds of Big Cypress Swamp, part of the Everglades.

Ever since then, Mr. Osbon and a handful of society members in on the secret say they have been making trips into the wild swamp country in hopes of meeting up with the mysterious intruder again.

Amid all the monster speculation, the Peninsular Archeological Society has not forgotten its basic purpose. Messrs. Osbon, Hudson, and others say that there are strange structures in the great swamp. There is even talk that this area, long ago, may have been part of the legendary continent of Atlantis.

"There are at least two pyramids and several walls in there," says Mr. Osbon. "The one pyramid is about 12 feet high and for the life of you, you can't tell where the rocks were fitted together. It has a tremendous amount of hieroglyphic writing and symbols on it. The wall is 4½ miles northeast of the pyramid and runs six or seven miles. It's made of stone slabs piled atop one another and stands six to eight feet high in places. The second pyramid is in water—12 to 14 feet sticking up out of the swamp."

Some society members speculate that both pyramids and wall are relics of an ancient race that inhabited Florida long before the Indians came.

Meanwhile, he's organizing an elaborate expedition, complete with remote-control cameras and other modern equipment, to go into the Big Cypress next month and find out once and for all about Yetis, pyramids, and walls.

Rock calendar believed found

ROCHESTER, Mich. (AP) — An Oakland University anthropology professor has discovered a group of rocks which he believes may be a Stonehenge-like calendar built by prehistoric Indians.

If his theory proves correct, it would be only the second such rock grouping discovered in this country, he said. A similar astronomical lineup has been discovered near St. Louis.

Prof. John B. Huner said his find could prove prehistoric Indians had a knowledge both of astronomy and geometry.

Huner will probe his theory soon when he begins excavations at the still-secret site. He said he is keeping the rocks' location secret lest amateurs ruin the condition of his find.

Stonehenge is a circular arrangement of huge slabs of rocks scientists think were used by Druids in prehistoric England for sun worship and to predict the sunrise, moonrise and seasons.

Old New England Stones Puzzle Experts

GREENFIELD, Mass. (UPI) — Atop a mountain about 12 miles west of here stand a half-dozen stones smaller than a man, larger than a child — mysterious in their symmetry and curious because, archaeologically, they are in the wrong part of the world.

Their meaning and the origin of whoever placed them there are a matter of conjecture, but to some experts they are further evidence that an ancient European culture had settled in New England long before Christopher Columbus made his Atlantic crossing.

THE STANDING stones are contrary to popularly held be-

liefs about New England's antiquity. Some archaeological quarters claim there was no European contact with North America before Columbus.

"Those stones shouldn't be there," according to James P. Whittall Jr. of Loudon, N.H. head archaeologist for the New England Antiquities Research Association, a group dedicated to unraveling the mystery surrounding many strange stone structures and formations found throughout New England.

Whittall said there are no other known formations in this region quite like that found atop this particular hill in Western Massachusetts. But, he emphasized, "I have seen

many similar sites in the British Isles, places where a Megalithic (stone-building) culture thrived thousands of years ago."

WHITTALL has made several trips to Europe seeking to establish links between the strange stone works in this part of the world and those known to have been part of that old Megalithic culture. The correlation between what he has seen and this site, he said, is extremely strong.

What makes him so certain, he said, is the pattern in which the stones are laid out. Also, they are on top of a mountain (1,858 feet above sea level) that provides a nearly unob-

structed view in all directions, a point to be seriously considered in view of the fact that the ancient stone cultures used similar locations and layouts for religious and astrological purposes.

Those ancients, it is believed, selected high places because it brought them nearer to the heavens. From this hill-top one can see for more than 40 miles, to Mt. Monadnock in New Hampshire on the distant horizon. It also is ideal for viewing the movements of the sun, moon and stars.

"AND THE STONES obviously have been shaped," Whittall said, "an important distinction."

COMMENTARY Each week thousands of letters cascade into the Personality Parade department of this publication.

Prior to Watergate, 70 percent of our letter-writers signed their names.

Since the Watergate scandal, 70 percent of our letter-writers request that only their initials be published.

Here is a sampling: "Do not print my full name. I don't want the FBI investigating my family... Initials only, please. Wouldn't care to make the Enemies List... Under no circumstances are you to

use my name. I've had enough trouble with the Internal Revenue Service ... Just print, if you use my letter, the name Mary B. I'm afraid of being hassled."

It will be years before the FBI, the CIA, the Justice Department, the Presidency, and various other branches involved in the shabby Watergate mess regain the confidence and respect of the American citizenry.

The major crime, the heinous sin, of Watergate is that it instilled in the hearts and minds of Americans a fear of their own government.

THE DEATH OF 18 MATERIAL WITNESSES IN A SHORT TIME

In the past decade more than 40 people who were directly, or indirectly connected with the assassination, either as witnesses or participants in the lives of those involved, have died strangely (179). A list of 18 "material witnesses," that is, people who could have been called to testify in the event that Lee Harvey Oswald had stood trial, perished in a shorter period of time. The list, and the methods which caused the death of these witnesses, pro-

vides some important data.

"Of the 18 witnesses, 5 died of natural deaths, and 13 were the victims of accident, suicide or murder. The unnatural causes constitute 71.5 per cent of the total. There were 6 murders, 1 manslaughter, 2 suicides, 3 motor vehicle accidents, and 1 presumed accident (or suicide) by a fall through a plate-glass window." (180)

An actuary of the London Sunday Times computed the life expectancy of 15 of the deceased witnesses and concluded that on November 22, 1963 the odds against all 15 being dead by February 1967 were 100,000,000,000,000,000 to 1 (181)

TRIVIAL ANNOUNCEMENT. ANOMALY #13 will probably be our final issue. It'll be a big one and a collector's item. Soon we will be announcing a brand-new professionally printed publication to be sold on a subscription basis. To be sure of getting lucky #13 send in your stamped (20¢!) self-addressed manila envelope now. If you have already sent several envelopes for future issues they will be returned to you with #13. Specialized Research; Box 351, Murray Hill Station; New York, N.Y. 10016.

SUBSCRIPTION PROBLEMS. If you are having problems with your subscription not arriving on time, it may be because you are basically an anal retentive personality and are obsessed to an unhealthy degree with "regularity." If you are not receiving issues at all, it is

probably because you are subconsciously punishing yourself for an imagined misdeed that went unpunished when you were a child, and you are deliberately losing your issue or hiding it from yourself after it arrives.

Watergate

17. Eight persons killed with regard to funding:

(1) *Mrs. Dorothy Hunt* — Carrying \$40,000 cash, not \$10,000, from Bernard Barker's account. Also with \$2,000,000 in securities, bonds, money orders. Killed on Flight 553, United Airlines, Dec. 8, 1972. Mrs. Hunt had said her "husband knows enough to impeach Nixon."

(2) *Rep. W. Mills*

(3) *Col. J. Webster* — Campaign manager for Mills

(4) *James Glover* — Second in command of W. Mills

\$25,000 in mysterious funds went through Mills' account. He claimed he didn't know where it was from. Two men who would know are dead. Maryland money is important because of the Wallace shooting in Maryland. There are a lot of people who would be paid off or silenced to cooperate with the plans.

(5) *Mr. Taub* — Allegedly working for Herb Kalmbach. Died in Switzerland. He was supposed to have \$2,000,000 on him, the same amount Dorothy Hunt had when she was killed.

(6) *Dennis Salvatore Cossini* — Contact man from CIA with Arthur Bremer. Could have provided the money, like Mrs. Hunt, be the cut-off.

(7) *Mrs. A. Topping* — Wife of Andrew Topping, man hired to kill Nixon. \$1,000 was paid to a Secret Service agent. This could be traced. Did any of the money come from Watergate money? Mrs. Topping was murdered because of something she knew. She was part of her husband's team. Although her death was listed as "suicide," like Rep. W. Mills, Topping said it was murder.

(8) *Lou Russell* — Carl Oglesby in the *Boston Phoenix* (July 31, 1973) refers to "the recent death of Lou Russell, an old-hand security cop employed by McCord Associates on the Republican convention security contract. He brought about a dozen checks in different amounts from McCord to Fensterwald's Committee to Investigate Assassinations during a period in which McCord and Fensterwald are not supposed to have known each other."

STENDEK

The Last Word



The Bettmann Archive, Inc.

Demon, by Albrecht Durer
Is there one in all of us?

limped away, but was seen later by another motorist on U.S. 27. Patrolman Robert Holmeyer of the Hialeah Gardens police is also supposed to have glimpsed the critter.

PUNGENT PLUGS: The Baum Bugle, a newsletter for devotees of the Wizard of Oz books by Frank Baum, now has a circulation of 1,200. It's published in Kinderhook, Ill. and costs \$2.50 per year..... If assassinations, conspiracies and political plots are your bag you might be interested in the Conspiracy Newsletter edited by Mae Brussell. Costs \$6 for 24 issues; 595 Broadway, N.Y.C. 10012. Dr. Leon Davidson, once a well-known figure in ufology, also puts out a conspiracy-oriented newsletter, Inside, Straight, \$10 per year; Blue Book Publishers, 64 Prospect St., White Plains, N.Y. Ramona Clark is preparing a new journal called Dimensions. For details write to P.O. Box 50605; Jacksonville Beach, Fla. 32250. ...SAGA magazine will be issuing a UFO quarterly this year with all new material. Costs \$3.00 for four issues; 333 Johnson Ave., Brooklyn, N.Y. 11206. This will be a professional job so don't miss it...Viking seems to be keeping Major Keyhoe's new book a secret- part of the great Air Force conspiracy, no doubt...The book to watch for this year is Brad Steiger's blockbuster, The Reality Game...And I will be coming out with a little surprise in 1975.

My thanx go out to all of you who sent me clippings and reports about local sightings during the great October wave. I regret it has been impossible to personally acknowledge receipt of all these items. Please believe they are greatly appreciated. I am compiling charts and graphs from this data and they will appear in a future ANOMALY. Apparently the Wednesday phenomenon was valid in some states while Thursdays proved more active in others.

The UFO phenomenon seems to have moved on to South America and Scandinavia in recent months and the anticipated great March-April wave in the U.S. may not materialize this year.

Mystery submarines reappeared in the Norwegian fjords in Nov.-Dec. '73, driving the Norwegian Navy bananas. New HITI (holes in the ice) turned up in several Swedish lakes in Jan. '74, prompting new official investigations...all very hush-hush.

On Wed., Jan. 6, 1974, Richard Lee Smith, a motorist in Fla., allegedly collided with a 7 foot "skunk ape", denting his car. The hairy monster

JOHN A. KEEL