



ISSUE NO. 40

JUNE, 1992



170 Strathcona St.,
Cambridge, Ontario,
Canada, N3C 1R4

519-658-6775

CAMBRIDGE UFO RESEARCH GROUP NEWSLETTER - JUNE, 1992

Our guest speaker for the March meeting was Victor Muscat, of the Canadian Raelian Movement. He presented the viewpoint adopted by their organization. It provided for much controversy and Victor had to defend himself against the verbal attack he received. A copy of an article pertaining to this group appeared in the local newspaper and this article follows.

For our April meeting, we had a new member, Henry Romanburg, speak. He moved from Argentina to Ontario and collected many reports while living there. Henry saw a UFO when he was 12 years old. He believes there is a UFO base in Argentina. He discussed cases with UFO photos and cases involving teleportation.

- man saw 10' beings that came out of a craft, witness shot at craft and beings.
- Henry found sightings to be in a straight line, running from city to city
- showed us newsclippings from Argentina
- Argentina navy documented UFO sightings and took UFO pictures, there was no clamp down on navy reports
- another witness saw 10'tall beings looking through garbage, they were carrying a red light, they lifted the light and without any effort, flew over the fence.
- in Brazil man saw craft and 3 beings and shot at them. When craft left the witness flesh started to disintegrate and fall off. He was reduced to bones and expired.

Henry provided us with a very interesting talk. He showed us many UFO photos taken in Argentina.

Attached is a report on South American Humonoids, which appeared in "Strange Magazine", #9, Spring-Summer, 1992 issue, P.O. Box 2246, Rockville, Maryland, 20847.

For the last meeting before our summer recess, we had one of our members as the guest speaker, Stephan Szpular. He has spent 20 years into the research of theology and to say he has a lot of data, is putting it mildly. He began his presentation by asking 33 UFO related questions. Then we viewed the program highlighting ancient astronaut/artifacts, we then watched a section of the movie "Intruders", based on the book by Bud Hopkins. (This was a 4 hour TV special on the weekend of May 18th.) We also watched a tape on the Belgium UFO sightings. Time did not permit watching other segments of tapes he brought.

Stephan then spoke about his own independent research and study into ancient biblical patterns and philosophy. He spoke about Immanuel Velikovsky's findings in his book "World's in Collision". He talked about Egyptian history, and the Hebrew, Enoch. He provided a multitude of information.

Unfortunately, the evening went too quickly and he couldn't complete his talk. Another meeting will be held in the fall to hear more on his theology research.

A new member brought questionable photos to the meeting. The photos were given to Phil by a retired gentleman who took the photos in the Jasper mountains in Alberta, sometime in early 1970's. He did not see the object when he took the photos. He gave the photos to Phil, who shared them with the group. These are the original photos, which the photocopying cannot do justice. Look carefully and you will see the craft has moved very slowly through the sequence of photos. If anyone has any comments on the photos, I'd be happy to receive them.

Have a happy and warm, we hope, summer!

Bonnie Wheeler

Bonnie Wheeler, President,
Cambridge UFO Research Group.



BONNIE WHEELER

If you wish to receive informations on the Raëlian movement's activities or to have a free video presentation about the ELOHIM'S messages given to Raël, please contact:

CANADIAN RÆLIAN MOVEMENT
P.O. BOX 56 STATION D
TORONTO, ONTARIO M6P 3J5
(416) 769 - 1358

Canadian Raëlian Movement
P.O. Box 86, Youville Station
Montreal, Qc Canada H2P 2V2
Tel.: (514) 681-6263



Video : **"They're coming"**

For those of you who will be unable to attend our summer Seminar, we have thought of providing you with the next best thing to being there, a video film.

In this presentation you will see RÆL and the raëlians in action on the site where is given the seminar.

Each year, the members of the **Raëlian Movement** have the privilege to participate in a week of seminar, which is held in Quebec during the third week of July on a campground where naturism is permitted.

This high quality video presentation will enable you to share this electrifying experience with some of your friends, and by the same token you will have helped, in your own way, to spread the greatest message of **Peace, Love and Fraternity** ever to reach this Earth.

Price: \$24.95Can + tax (\$20.00US) + \$2.00 for postage and handling.



Sensual meditation **tape**

We are proud to be able to offer you a high quality recorded tape (voice and music) which will enable you to learn this **meditation technique**. The text and music were composed by Raël himself, and then translated into English.

This tape was specially designed for your enjoyment. It will fill your cells with a deep feeling of harmony and peaceful contentment.

Price: \$20.00Can + tax (\$16.00US) + \$2.00 for postage and handling.

Send your money order to:

A.R. 1973
P.O. Box 296
Boucherville, Quebec
Canada J4B 5J6
Tel.: (514) 655-9862 Fax: (514) 641-0310

I understand that I may return the book within 10 days and receive a full refund.



The book which tells the truth

Mankind was created scientifically in laboratories thousands of years ago. Our creators, the ELOHIM, are from another civilization, on another planet.

In the Bible, the Book of Genesis describes the work of the ELOHIM. The original Hebrew biblical text says "the first day ELOHIM did this; the second day ELOHIM did that, etc." Over the years, the term ELOHIM has been mistranslated to God. The original Hebrew term is a plural and can be literally translated to "Those who came from the sky."

There is no God, and no human soul which escapes the body at the time of death.

Moses, Buddha, Jesus, Mohammed, and all the great prophets, have been sent by the ELOHIM.

Jesus was fathered by an ELOHA, and born to an Earth woman. He was entrusted with the task of spreading the biblical message in anticipation of our Era, the Age of the Apocalypse, an Era where everyone is able to understand the truth.

We have been living in the Age of Apocalypse since 1945. The events of this age of revelation were predicted in the Bible: "the people of David would find their country again" (creation of the State of Israel); "the blind would be able to see" (electronic prothesis); "man would make his voice heard beyond the oceans" (telecommunications satellites); "and man would be equal to God" (scientific creation of synthetic human genes).

The ELOHIM have met with a young French journalist, Claude Vorilhon, whom they have given the name "RÆL". Raël has been entrusted with spreading their Message, which contains the truth about past events and a deep insight into future happenings.

**Price: \$12.00Can (\$10.00US) +
\$2.00 for postage and handling.**

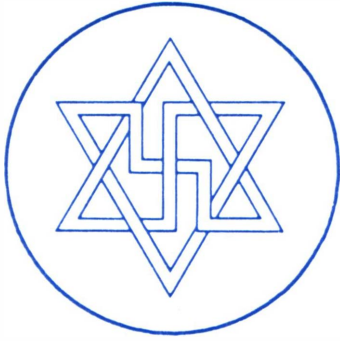

The symbol of Infinity

This is the oldest symbol known to mankind. It appeared in every great tradition, on every continent. For example, it was found on the Tibetan Book of the Dead, on the tombs of the first Christians, on ancient Hebrew scriptures in Rome, on the west wall of the Cathedral Notre Dame de Paris.



The Star of David represents the Infinity of SPACE: "that which is above is like that which is below". The Extra-Terrestrials, creators of humanity in laboratories, have proven scientifically that the infinitely small has the same structure as the infinitely great. The atoms of our hand, for instance, are but a minuscule gathering of galaxies made up of planets where humanities smaller than ours exist. Thus, the galaxies we are looking at in the sky are but an immense formation of atoms which form a gigantic world, and so on to infinity.



The SWASTIKA represents the Infinity of TIME. "Everything in the Universe is in perpetual transformation". This applies to the infinitely small as well as the infinitely great. Matter has had no beginning as it will have no end: EVERYTHING is CYCLIC. HERACLITE said in 500 B.C.: "Nothing is created, nothing is lost, everything is transformed".

The symbol of INFINITY is the emblem of those Extra-Terrestrials, who created mankind scientifically. The original Hebrew biblical text refers to them as ELOHIM (Those who came from the sky). This symbol is also the emblem of the Raelian Movement, founded by the ELOHIM's last Messenger, RAËL.

They're coming

They created humanity scientifically in laboratory, thanks to DNA

Their masterpiece was described by those primitive men, who first wrote the Bible.



**Who are they ?
What are they to humanity ?
Why have we been created ?
When will they come ?
Where do they want to meet ?**



Raelians say life was created by aliens

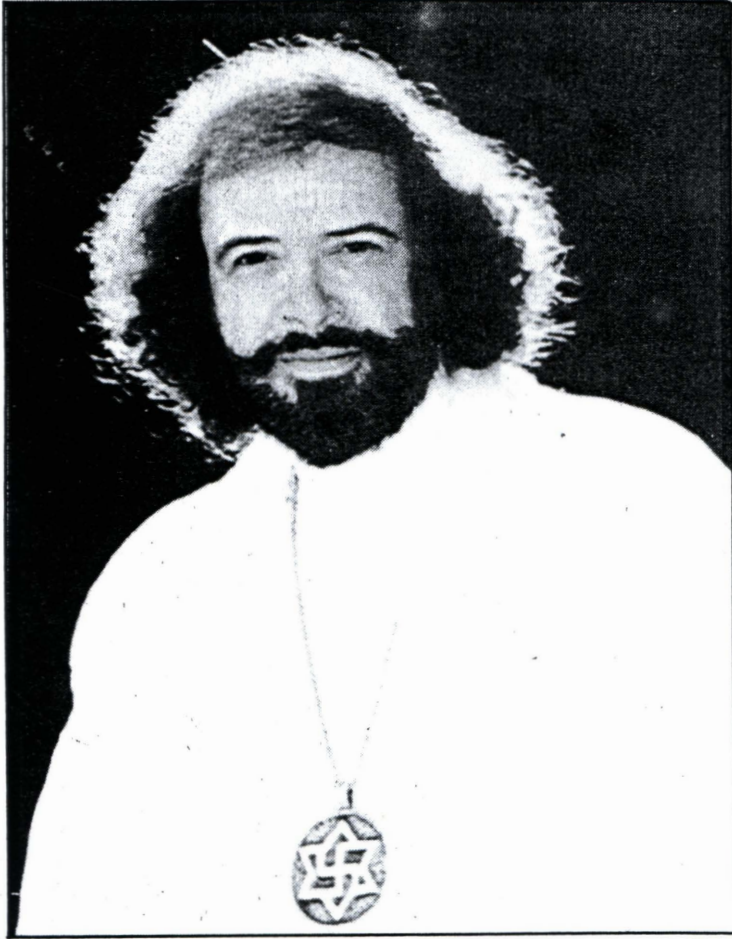

Raelians believe life on Earth was created by aliens who use a computer to judge every person's life. The group was founded by a former automotive writer from France named Rael (above).

RAELIANS

- In 1973, French writer Claude Vorilhon created the movement after he said he'd met an alien in the crater of an extinct volcano. Rael, as he now calls himself, lives in Montreal and Florida.
- There are 28,000 members worldwide and 7,000 in Canada, mostly in Quebec and Ontario.
- Members are asked to contribute three to 10 per cent of their incomes. Rael says he and all other leaders are unpaid.
- The movement espouses peace and love; practises nudity, free love and "sensual meditation."

VANCOUVER (CP) — The sound comes from deep within each of the assembled 17 people, low and strangely harmonic.

Ow-ummmmmmmmmmm.

Ow-ummmmmmmmmmm.

The tone rises and falls as voices hold the note, fall away for a breath and join in anew.

Marie-Louise Bussieres — guide and meditation leader of the local Raelian movement — calls a stop.

Silence.

"Feel the vibration in the air and in your body," she murmurs in her lyrical French accent.

The aim is to release feel-good chemicals in the body . . . for 3 p.m. is approaching. Time for the transmission of the genetic code to outer space — the most important ceremony for Raelians, who believe humans were created by aliens called Elohim.

As Raelians tell it, somewhere in interstellar space is a computer that serves as a repository of the transmitted genetic codes of earthlings and keeper of a balance sheet of human lives.

When people die, the computer spits out a report.

Those who have been good are scientifically re-created in a sensual paradise on the home planet of the human-like Elohim.

These beliefs come from a man known simply as Rael (pronounced Rail), a 45-year-old former automotive writer from France who founded an international movement that now claims 28,000 members.

"Some people believe I am crazy. I don't care," Rael said from New Zealand where he was promoting the group.

"None of them (followers) came to me saying 'I believe.' They all said, 'I thought that same thing before reading your book.'"

Rael's book, first published in English in 1978, is the group's bible. Entitled *The Message Given to Me by Extra-terrestrials — They Took Me to Their Planet*, it conveys a

message of peace, love and fraternity.

If enough people believe in the Elohim and show humanity to be worthy, the aliens will return — arriving at an elaborate embassy the movement hopes to build in Israel.

The Elohim's expected arrival date: before 2020.

"When you know where you come from, it makes you more harmonious because you know where you're going," says Bussieres, 49, a Vancouver French teacher.

"My life is dedicated to it. I'm so convinced I bring something good to humanity . . . it brings me so much joy, so much peace."

On reading one of the group's glossy brochures, philosophy professor Paul Russell of the University of British Columbia calls the movement wacky. But interesting.

"It's got this attractive blend," he says. "There's Christian credo, pseudo-philosophical content and science fiction. It's clever in that it's an attempt to demystify the Christian myth and give it a scientific twist."

But he suggests it's "too put together to be real."

One of the largest UFO research groups in the United States wants nothing to do with Rael's movement.

"Let him document his own claim," challenges Walter Andrus, international director of the Mutual UFO Network, a 4,000-member Texas-based organization which claims to "deal in" UFOs from the scientific viewpoint.

"Only the message itself is proof," responds Rael, who is said to be in telepathic communication with the aliens.

"A human being couldn't create it, write the Genesis of the Bible or create life in a laboratory," he says.

The Canadian Raelian Movement can be reached at P.O. Box 86, Youville Station, Montreal, Que., H2P 2V2.

Cambridge Reporter Monday May 25, 1992

UNUSUAL LONG-CHINNED HUMANOIDS

In the continuing effort to classify humanoid creatures, one should take note of the tall, usually silent, long-chinned beings which first appeared (according to my data) on August 28, 1972, and disappeared no more than seven months later. All of these cases happened in the Buenos Aires province. Here, briefly, are the reports.

The Deugd Case

Eduardo Fernandez de Deugd, 32, a mechanic of Bahia Blanca, was driving his old car back home on August 28, 1972, at 3:15 a.m.

He said he stopped the car to repair the antenna of the radio when a man—who hitchhiked using lettered signs—came into view. So, Deugd let the man into the car. The mechanic made small talk but the passenger answered with incomprehensible sounds. Deugd believed the hitchhiker was a man of few words, so resolved to continue driving without talking. After about 25 kilometers of further travel, the strange man apparently put his left hand into his pocket and the car lost power while its lights went out. Deugd sighted a bus-shaped luminous object, equipped with portholes, near the road. It seemed to land in a field. He got out the car, but quickly returned to it when he realized the "bus" was an unknown flying object. To his surprise, he saw the passenger was no longer in the car; meanwhile, the door had been opened and the door's handle wrenched off. Now the motor started without trouble. Deugd drove to and fro, but he could not find the man. The witness later said the strange hitchhiker was a 1.9-meter-tall man wearing a hat and a coat with the collar turned up. The man's chin was too long, reaching the middle of the chest. Partially confirming Deugd's sighting, night watchman Rodolfo Maisterrena said he saw some unknown lights hovering above the camps adjacent to the road.^{1,2}

The Coccioli Case

On October 4, 1972, Gilberto Gregorio Coccioli, 50, a resident of Burzaco, near Buenos Aires, awoke when he heard a noise in his backyard at 3:30 in the morning. He believed his dog was nervous, so went to calm it down. Suddenly, dazzled by a beam of light, he lost consciousness. When he woke up again, he saw that he was in a metallic room where there were some 2-meter-tall, very thin, khaki-clad men. They had extraordinarily long chins which reached their chests. Coccioli claimed the aliens contacted him by telepathy. They took blood samples from him and then forced him to have sex with two women. Coccioli added that the beings gave him an odd stone

INFREQUENT TYPES OF SOUTH AMERICAN HUMANOIDS

BY FABIO PICASSO

PART II of a series

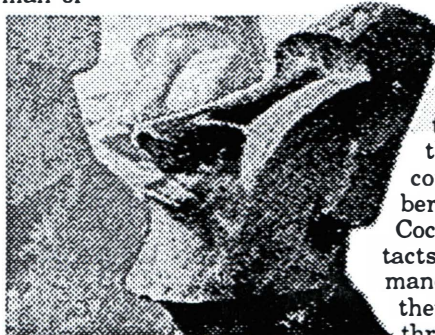

Easter Island head: reminiscent of South American long-chinned humanoid accounts.

Artist's reconstruction of Deugd's encounter. Cr. Gente. Artist: Abel Guibe.



as a gift. He concluded: "They keep in contact with me by a tingling in the nape of my neck."^{3,4}

The Balmaceda Case

This is the most controversial account because no researchers were able to interview the witness. I obtained this report from a newsclipping and have included it only because the beings were described as having long chins.

Robinson Balmaceda, 68, who lived in Avellaneda City near Buenos Aires, stated he got in touch with alien entities six years ago. He said the humanoids always appeared on March 11. His 1973 encounter began at 8:00 p.m. when two long-chinned men wearing ordinary clothes came into his room. They had white skin and seemed to speak with an

accent. Then, one of them showed him a device. The strange men said it could change anything into energy. They activated the artifact and reality seemed to "dance" around Balmaceda. Finally, the aliens left the house.⁵

These three cases were long discussed because of their high strangeness quotient. In all of them, the encountered entities were described as ordinary men except for their too-long chins. Deugd's and Balmaceda's contacts showed the most bizarre behaviors of the supposed alien beings. Balmaceda's encounters may have been similar to Doctor Herbert Hopkins' with Men-in-Black.⁶ Similarly, Coccioli's resemble present-day claims of contacts—mainly in the United States—where humanoids supposedly kidnap people, examine them, and implant little tracking devices through their nostrils and ears. Unfortunately, Coccioli did not undergo analysis, X-rays, or hypnosis.

There are only two supposed cases of so-called "tracking devices" in Argentina. One of them occurred in Buenos Aires in May 1968, discussed in an article by the late UFO investigator Americo Barrios.⁷ The other took place ten years later, near Bariloche, and was long-studied by researchers of the *Cuarta Dimension Review* of Buenos Aires.⁸

CYCLOPEANS

Cyclopeans have been known as mythological beings since Homer's *Odyssey*. Such authors as Empedocles, Athanasius Kircher and Boccaccio stated that a skull of an elephant—seen from the front—could be taken for a one-eyed being. Many others believe Cyclopeans are figurative representations of volcanoes.⁹ Taking a different tack, researcher Peter Kolosimo said the correct translation of "Cyclops" is "round-eyes" not "one-eye" as everybody supposes.¹⁰ Whether real or not, Cyclopeans are still seen, at least in Latin America. I have found 11 supposed cases where the witnesses reported Cyclops-like entities. Unfortunately, most of them are from newsclippings and no specialist research-

ers were involved in the investigation. Nevertheless, I will summarize the reports.

1) *March 1960—Salta, Argentina:* A strange being appeared in the Yariaguarenda forest, sowing panic throughout the whole region. The Tartagal Mountaineering School Battalion was put on alert for the presence of a powerful, cyclopean, 2.4-meter-tall being, but what came of it is unknown.¹¹ Interestingly, I have found another clip where an unknown correspondent stated that the story was a hoax.^{12,13} However, report number 2 below and some tales well-known in the provinces of Salta, Tucuman, and Jujuy relate similar accounts of a Bigfoot-like being called "Ukumar Zupai."

2) *October 1960—Salta, Argentina:* An odd, tall, cyclopean being was seen again in Yariaguarenda, not far from Tartagal City. The 200 kilogram monster—called Ukumar Zupai by the natives—has attacked two women and a child.¹⁴

3) *August 28, 1963—Sagrada Familia, Brazil:* Two brothers, Fernando and Ronaldo, and another boy, Jose Marcos, were in a backyard when a beam of light illuminated the area. The boys saw a ball-shaped transparent object with four cyclopean entities (three males and a female) within it. They wore tight overalls, and one of them got down and out of the UFO floating in the air. He communicated with the children by signs and unknown sounds, and finally by telepathy. Then he rose through a beam of light to the object, which went away.¹⁵

4) *February 1965—Torrent, Argentina:* Señor Sourriou and some farm laborers were returning home after a nocturnal hunting party when they sighted five small shapes. One of the farm laborers attempted to attack them, but they grew to no less than 2.5 meters in height. Sourriou tried to shoot them, but, for some odd reason, the gun failed. The frightened men ran away and shut themselves up in the house. The light the beings gave off seemed to filter through the walls of the house. Sourriou attempted to escape, but the humanoids pursued him. One of the entities grabbed him with its hairy hands but he eluded the being. Finally, the witnesses were able to get away by van. The strange, thin humanoids each had only one eye.¹⁶

5) *February 21, 1965—Chalac, Argentina:* One or more silvery objects allegedly landed near a village of Toba natives and three tall, cyclopean luminous beings emerged from within. It is said that the natives worshipped the beings. There have been claims that policemen took photographs of the scene, and that these were seized by Argentina's Air Force.¹⁷ It now seems certain that this event was a hoax.¹⁸

6) *August 30, 1965—Arequipa, Peru:* A cyclopean, bush-like little being was seen on Panamerica Highway by two witnesses, who said they believed the alien was 0.8 meters in height. When the bush-like thing disappeared, a UFO flew over the car.¹⁹

7) *September 8, 1965—Puno, Peru:* Eight 0.8-meter-tall, cyclopean entities were sighted by a ten-year-old boy. He summoned his parents, who saw a strange light going up into the sky.²⁰



Witness's drawing of cyclopean entity in the August 28, 1963. Sagrada Familia, Brazil case.



8) *September 29, 1965—Arequipa, Peru:* Two persons almost knocked over a small, cyclopean being with their car. The 0.8-meter-tall alien's body was covered with luminous ribbons. Shortly afterwards, a UFO hovered over the percipient's car.²¹

9) *October 9, 1969—Laguna Blanca, Argentina:* Señor Lotcket stated that the motor of his van stalled while he saw a UFO with three 0.8-meter-tall creatures inside it. The entities had blond hair and seemed to be Cyclopeans. They were only 10 meters away from Lotcket. Some burnt plants were found in the area.²²

10) *March 30, 1979—Cardenas, Mexico:* Two children coming home from school saw twenty little one-eyed men moving quickly. The 0.5-meter-tall beings were enveloped in light and floated up into the sky.²³

11) *October 28, 1988—Pergamino, Argentina:* Four young men were walking along a road at 12:30 a.m. when they sighted five or six little green men. The beings each had no hair, only one eye, hands with three fingers, and moving arms. The entities seemed to walk joined together as a block, and were growling. Frog-like tracks—thought to be theirs—were later found.²⁴

Cyclopean beings can be classified into two subtypes. There are short Cyclopeans as in cases 6 to 11, and tall ones as reported in 1 to 5. The latter beings often behave aggressively (2 and 4). They may even be as hairy as Bigfoot (4). Some beings, despite their height, can levitate (3, 4 and 10) or emerge from transparent UFOs (2, 4, and 10). They communicate with their witnesses by telepathy (3) or by words (6).

Tall Cyclopeans were seen from 1960 to February 1965, while short ones have appeared since August 30, 1965. At present, the latter subtype is the only one reported.

Finally, all cases, except No. 10, were situated in a region between 16 and 34 degrees South Latitude.

EPILOGUE

Encounters with extraterrestrial beings were once considered fantastic tales. Today, many investigators—in my country as well as worldwide—have specialized in the so-called Close Encounters of the Third Kind. Humans sighted bizarre creatures first and later began to classify them. At present, some types are not reported in certain countries, while others appear more frequently in one region or another. Despite the neglect of hundreds of cases because of the shortage of the means and manpower to investigate them, it is necessary to create a new classification system covering the thousands of encounters reported even in distant countries. If Jader Pereira, two decades ago, could exhaustively analyze 333 cases, it is worth attempting the same thing again with the help of computers and the input of as many researchers as possible.

See footnotes on page 55



Next issue: A red giant, gelatinous monsters, robots, gnomes and little green men in South America







THE ISLANDER PENSACOLA, FLORIDA
NOVEMBER 15 1991

UFO Investigators Photograph Unidentified Object Over Beach

By Gary Watson

On November 5, an unidentified object was seen and photographed as it hovered over Gulf Breeze. A dozen witnesses and several MUFON (Mutual UFO Network) investigators saw the UFO from the south end of the Bay Bridge.

Photographs were taken by Patti Weatherford and Anne Morrison who used a 440mm lens and fast action 3200 ASA film to capture the image of the "crown" shaped object.

The object seen on this night is believed to be the same type UFO first reported by Ed Walters and scores of other witnesses in 1987. The configuration of "portholes" and the very bright bottom "power" light resembles the outline of the UFO that Ed Walters described in his best selling book "The Gulf Breeze Sightings."

The UFO sightings in Gulf Breeze have been occurring at a record pace since the first of the year, but recently the UFOs have displayed a variety of effects. Before the eyes of scores of people who gather nightly at the Bay Bridge, spectacular rings of lights have appeared

from "out of thin air." These rings of light are made up of separate points of light that often hover making no sound and then suddenly vanish in a clear sky. Often the witnesses can see the structural shape of the object as it travels across the sky and blocks out the stars as it passes. This was the case with this latest sighting when one very skeptical witness looked through his binoculars and said, "Hold on here, I can see something black around it." Another witness, Bland Pugh said, "I could see a definite

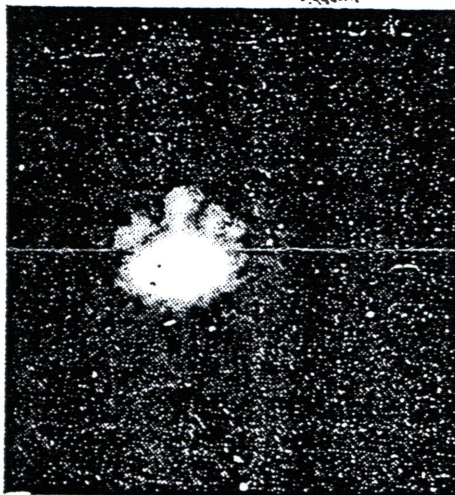

Patti Weatherford snapped this photo of the latest UFO to appear in the skies above Gulf Breeze.

curved structural shape above the blazing red light at its bottom."

NASA project to seek signals from alien life

Associated Press

PASADENA, Calif. — NASA is celebrating the 500th anniversary of Christopher Columbus' arrival in the New World with a \$100 million project to search for extra-terrestrials.

The National Aeronautics and Space Administration will begin setting up equipment in the Mojave Desert next week to carry out the search, which will begin on Oct. 12, Columbus Day.

The holiday was picked because "it celebrates the spirit of exploration," said Michael Klein, manager of the Jet Propulsion Laboratory's portion of the Search for Extraterrestrial Intelligence.

"What we are trying to understand is ... are we alone in the universe and what is our part in this incredible universe?" Klein said Thursday. "I strongly believe someday we will make contact with other civilizations."

More than 50 searches for alien life have been conducted since 1960, scanning the heavens for radio signals generated by an intelligent civilization in the Milky Way or other galaxies.

NASA's \$100 million effort will be the most extensive ever. It will scan the entire sky for a range of frequencies, conducting a highly sensitive search for radio signals from planets that may exist around 1,000 sunlike stars within 100 light years — 588 trillion miles — of Earth.

"Circumstantial evidence suggests countless Earthlike planets exist in our galaxy," Klein said. "We hope someday we'll detect the existence of other intelligent civilizations from those planets."

Scientists eventually will use sophisticated radio-signal analyzers and giant dish-shaped antennas already located at NASA's Deep Space Network tracking stations at Canberra, Australia; and Goldstone, Calif.

JOHN F. SCHUESSLER
P. O. BOX 58485
HOUSTON, TEXAS 77258-8485

1/18/92
ROCKY MOUNTAIN NEWS

A one in a million disaster

Scientists propose plan to save Earth from asteroid crash

Knight-Ridder Newspapers

MOUNTAIN VIEW, Calif. — The chance that the Earth will be struck by a mile-wide asteroid in the next year are greater than the chance that any given person will be struck by lightning — about 1 in a million. But since an asteroid that size could destroy half the planet's population, some NASA scientists say it's a statistic worth worrying about.

"We know that the Earth exists in a swarm of comets and asteroids," said David Morrison, chief of the Space Science Division at NASA Ames Research Center in Mountain View. "With the amount of sky coverage we have today, it would be very unlikely that we'd spot it before it hit."

About 10,000 asteroids have orbits approaching the Earth, and tracking them would require at least six telescopes with 2- to 3-meter mirrors distributed throughout the Northern and Southern hemispheres, Morrison said. As chairman of a 23-person committee of astronomers commissioned by Congress to study the potential problem, Morrison will ask Congress later this year to support a thorough comet and asteroid tracking project.

The six telescopes, "moderate in size by today's standards," would cost \$12 million each, Morrison said.

Using three smaller telescopes in the United States and Australia, astronomers are now tracking comets and asteroids at the rate of one or two a month, Morrison said.

Although there is a slim chance that a giant asteroid could strike the planet at any moment, Morrison says that with proper tracking techniques, astronomers could spot a catastrophic one decades before it would hit the Earth.

Spotting it, however, is only half the battle. The next step would be to go out and meet the meteor, deflecting it from its collision course with the planet.

"The simplest way, we think, to give it a shove is to set off a nuclear bomb next to it," Morrison said, explaining that changing the asteroid's speed by even 1 centimeter a second could avert catastrophe.

The resources needed to spot the deadly asteroids may begin at \$72 million, but the technology to stop them may indeed be out of this world. Before sending a bomb or two beyond the Earth's atmosphere, astronomers would need to send spacecraft to the asteroid to discover what it's made of and to study its exact

position and speed. Asteroids can be made of metal or rock, and comets are usually made of ice, all of which would react differently to a nuclear blast.

If the telescopes could enable astronomers to see the deadly meteors years before hitting the Earth, scientists would have time to develop the technology to stop them, Morrison said.

"I'm not pretending that it's easy, but if you allow several decades, there's no doubt in my mind that we could do it," Morrison said. The project that the 23-astronomer team will propose before Congress this year, however, focuses only on spotting the problems, not stopping them, he said.

An asteroid a mile in diameter would hit the Earth at about 15 miles a second, producing an explosion akin to a million megatons of TNT. Dust and particles produced by the blast would block about 90 percent of the sun's rays and lower the planet's average temperature by 10 to 20 degrees for several months, "until the dust settles," Morrison said.

Scientists say all the world's crops would be destroyed for an entire year, causing half the population to die of starvation.

4A

★★★

Houston Chronicle

Sunday, Sept. 29, 1991

What's that UFO? Experts disagree

Newsday

The strange object now sneaking toward Earth from outer space is probably a spent rocket that boosted a sun-watching spacecraft into solar orbit in 1974, some astronomers said Friday.

The object is probably an old Centaur upper-stage rocket involved in the U.S. launch of a Helios craft, said astronomer Brian Marsden of the International Astronomical Association in Cambridge, Mass.

Other experts disagree. Astron-

omer Donald Yeomans, at the Jet Propulsion Laboratory in Pasadena, Calif., prefers another launch, such as the Pioneer 4 mission to the moon in 1959, as the source of the space debris.

The object was noticed on Nov. 6 while 2 million miles away. Between about 1 yard and 10 yards in size, it will come within 300,000 miles of Earth on Dec. 5, and then drift away again.

Several other astronomers at the Johnson Space Center in Houston agree with the Helios idea. Marsden is also seeking data on possible Soviet launches.

Scientists: Nuke killer

THE chance you could be killed by an asteroid slamming into the Earth is more than triple the chance you could be killed in a plane crash—one in 20,000, compared with one in 6,000. Those probabilities come from NASA, where astronomers say the Earth will eventually be destroyed by an asteroid. "The Earth is certain to be hit,"

asteroids to save the Earth

says Dr. Clark Chapman of the Planetary Science Institute. "We just don't know when." To prevent that, physicist Edward Teller, father of the hydrogen bomb, suggests "sending out a little something to meet it." A nuclear bomb could explode any asteroid aimed at Earth, says a Lawrence Livermore National Laboratory report.

8A

Houston Chronicle

Saturday, Nov. 23, 1991

STAR August 20, 1991

17

HOT NEW TOURIST ATTRACTION

Kievturist is arranging package tours to Chernobyl in the Ukraine, the site of the world's worst nuclear accident to date. The tour's price of 25 rubles includes a trip to the local treatment center—if a tourist should get overexposed to radioactivity. Source: *San Jose Mercury News*, 2/4/91

HAIRY HOME

Things were spooky enough at the home of Elena Pacheco and her daughter, Delma Robertson—then the bathroom grew hair. The house is only twenty years old, yet strange voices are heard in the corridor, furniture moves by itself and the bed sheets sometimes fly about.

Ms. Robertson is convinced that "psychic phenomena" has manifested during the twelve years the family has lived there. "But when this thing happened, I knew something was going on in this house without a doubt," she said.

Both mother and daughter claim that short, whiskerlike hairs recently began sprouting from a bathroom wall.

When a reporter came around, only one hair could be seen emerging from the wall—the others had been piled on the sink.

Ms. Robertson planned to have a priest bless the home, and was also in need of a psychic. Source: *The Daily Breeze*, 10/31/90



IF SHE WERE PSYCHIC, SHE'D HAVE SETTLED

Home Depot Inc. had offered to settle the lawsuit that Penny Pellito and her husband James had placed against the company, but the couple wanted to hold out for \$1 million in damages. So instead of the \$17,000 the Pellitos of Miramar, Florida, might have received from the settlement, they ended up with \$2,000 instead—\$1,000 each. This was only a token sum for the non-paranormal injuries.

It seems that they could not make the Broward Circuit jury believe that Mrs. Pellito had lost her psychic power to undergo pain-free surgery without anaesthesia, because of an April 1987 accident—at the Hollywood, Florida, branch of the Home Depot store—in which lumber had dropped on her head.

So the jury came to its decision on February 8, 1991. Harry J. Weintraub, one of their number, said, "I think she has something. It's amazing, it really is. I never doubted she had that ability." He opposed her paranormal damage claim because she had not proved to his satisfaction that she had lost her power or was unable to retrieve it.

Sources: *San Jose Mercury News*, 2/8/91 and 2/9/91

Farcus

by David Waisglass
Gordon Coulthart

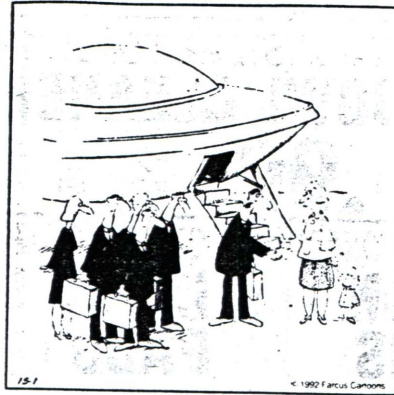

“Greetings. We seek new markets.”

Notes from the Hangar

The National UFO Museum's quarterly journal of UFOlogy, *Notes from the Hangar*, is now available to the general public. With a lively letter column, cutting edge articles, probing book reviews, in-dept interviews and fascinating Close Encounter Reports this is a must read. 64 pages, digest size. While subscriptions are only available to members of the museum's Friends of the Museum Association, individual copies may be obtained by sending \$4.95 (postage paid in the U.S., add \$1.00 for Canada, \$2.00 for over-seas Air Mail) to:

National UFO Museum™

Administrative Offices located in The Professional Building,
150 N. Center St., Suite 223, Reno, NV
89501-1603 U.S.A.

Want to know more

about the

National UFO Museum™?

Please send \$2.00, to cover the expenses of postage and handling, to be placed on our mailing list. You will receive an exciting informational package about NUFOM™, our goals, plans and activities. You will also receive our current catalog of selected bookstore and gift shop items.

You may write us anytime to share your views and feelings on UFOs and Ufology, and especially to send in any UFO close encounter reports!

National UFO Museum

150 N. Center Street, Suite 223, Reno, NV 89501-1603 U.S.A.

If mysteries be your madness, savour these books. All five of them were written or compiled by **John Robert Colombo**, who is nationally known as "the Master Gatherer" for his innumerable books about Canada. Lately he has been dubbed "Canada's Mr. Mystery" for his publications in the field of paranormal Canadiana.

Doubleday Canada is the publisher of **Mysterious Canada**, a 436-page volume with 114 illustrations that is devoted to the country's major and minor mysteries of the past and the present. It is available in two editions: cloth (\$29.95) and trade paper (\$19.95).

Hounslow Press is the publisher of trade paperback editions of these four books (at \$14.95 apiece): **Extraordinary Experiences: Personal Accounts of the Paranormal in Canada...Mysterious Encounters: Personal Accounts of the Supernatural in Canada...Mackenzie King's Ghost and other Personal Accounts of Canadian Hauntings...and UFOs over Canada.**

These books as well as other books by **John Robert Colombo** are available at better bookstores across the country.

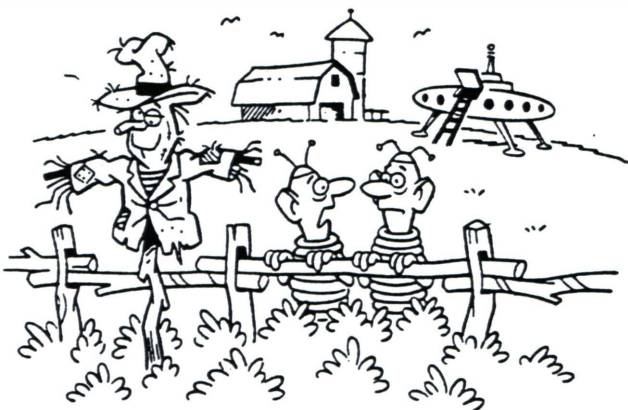

"YOU TRY--I CAN'T GET A WORD OUT OF HIM!"

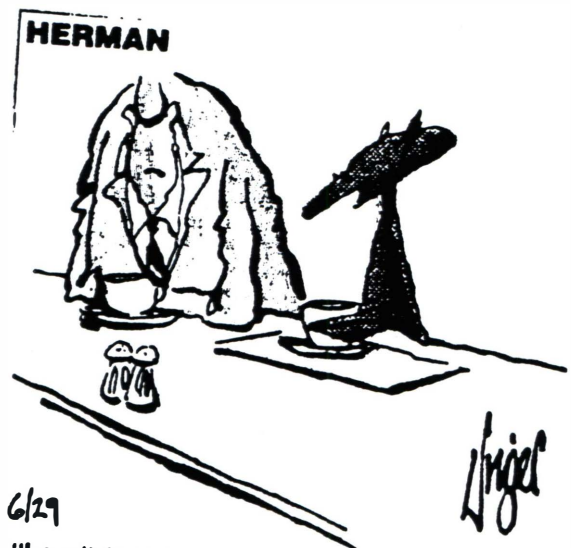

6/29

"I can't face the next thousand years without my cup of coffee."

STRANGE

MAGAZINE

Twice a year, the top researchers, investigators, theorists, and writers in the field of strange phenomena bring you a fantastic collection of well-documented articles, features and columns covering all aspects of the anomalous and unexplained.

Premiere Double Issue #1
\$7.95 US £5.50 UK 84 pages

The Abduction Enigma (14 pages)
The Mysterious Crystal Skulls:
The British Museum Skull
The Alien Visitors of Charles Fort
(Ancient Astronauts)
UFOs, Lake Monsters, High Strangeness,
Blobs (Slime Molds), Archaeological
Anomalies, Death Rays, Bob Rickard
Profile, Kinderhook Ghosts, and more.

Issue #2 \$7.95 US £5.50 UK 64 pages

Robert Anton Wilson vs. CSICOP
The Strongest UFO Cases
Including Stanton T. Friedman on the
Roswell Incident; Keel on Fatima;
Shoemaker on Cash-Landrum; also
Randles, Girard, Maccabee & Stacy
Mad Scientists and the Movies
Paul Devereux on Earth Mysteries, Loren
Coleman's Cryptozoo News, Janet Bord,
Greek Forteana, more.

Issue #3 \$7.95 US £5.50 UK 64 pages

The Mitchell-Hedges Crystal Skull
Dr. Bernard Heuvelmans on Sea-Serpents
John A. Keel on Hallucinations, UFOs, and
Fortean Investigations
Lizardman—The Whole Story
Monsters of Maryland: Bigfoot (Part 1)
Debunking the Debunkers: Vinland Map,
Alien Skies, High Strangeness, Janet Bord,
Coleman's Cryptozoo News, 1988 "Ten
Strangest" List, Wilhelm Reich & more.

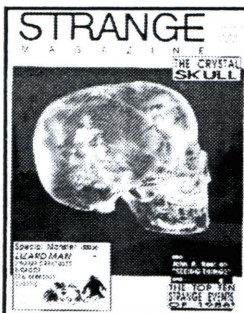

Issue #4 \$7.95 US £5.50 UK 64 pages

The Selbyville Swamp Monster
Yeats and the "Little People"
Psychic Warfare
Lifefall: Did Life Arrive on Meteorites?
Fortean Falls in Greece
UFOs, Ghosts & Time Slips
Monsters of Maryland: Bigfoot (Part 2)
Shroud Dating Scandal, Megamouth, UFO
News, Forteana and Folklore, Coleman's
Cryptozoo News, Keel Files, & much more.

Issue #5 \$7.95 US £5.50 UK 64 pages

Special Issue: Monsters & Mystery Animals
The Mystery Photograph Solution by Mark
Chorvinsky; Cryptozoology in the Land of
Shadows by Loren Coleman; John A. Keel
Interview; Historical Bigfoot; The Unknown
Lake Monsters of Alberta; Carl Hagenbeck
and the Rhodesian Dinosaurs; Lake
Champlain's Monster Fossil; King Kong;
The Monsters of Maryland; The Monster is
a Man; 1989 "Ten Strangest" List; & more.

Issue #6 \$6.95 US £5.00 UK 64 pages

Jack Parsons: Sorcerous Scientist
Investigating UFOs by John A. Keel
Strange Personal Encounters
Cropfield Circles Articles
Dr. Bernard Heuvelmans on
Living Pterodactyls: Part 1
UFOs & Stalled Cars; UFO News; Keel
Files; Coleman's Cryptozoo News; Phone
Call from the Past; Bigfoot Research; 1990
"Ten Strangest" List; Haunts; & more.

Issue #7 \$6.95 US £5.00 UK 64 pages

Ultradimensional Mind:
The UFO-Psi Interface by Michael Grosso
The Mystery of the Mono Grande
Vincent H. Gaddis Interview
Celluloid Crowley by Douglas Chapman
Mentalist Theodore Annemann
Crop Circle Articles; Coleman's
Cryptozoo News; First Person Encounters;
Ball Lightning; Mixed Bag; Strange News
from Britain; & much more.

Issue #8 \$6.95 US £5.00 UK 64 pages

Tony "Doc" Shiels: Magic & Monsters—
"Mary F." Morgawr Photos Investigation; The
Shiels Tapes; Morgawr Unborn; Bob Rickard
& Michael McCormick Interviews; "G.B. Gordon"
Photo; The Trickster; Shiels on Surrealism
& Magic. Also: Ancient Japanese Visited
the New World; Red Eye Glow; Georgia
UFOs; South American Humanoids; Weird
Encounters; Crop Circles; Haunts; Coleman's
Cryptozoo News; European Falls; more.

SUBSCRIBE NOW. You won't want to miss one mind-boggling issue.

YES! I want to subscribe. Start my subscription with issue #9 #10 (10/92)
4 issues \$17.95 US • £13.50 UK • \$22.95 International • Published twice yearly

<input type="checkbox"/> No. 1 \$7.95 US £5.50 UK	<input type="checkbox"/> No. 6 \$6.95 US £5.00 UK
<input type="checkbox"/> No. 2 \$7.95 US £5.50 UK	<input type="checkbox"/> No. 7 \$6.95 US £5.00 UK
<input type="checkbox"/> No. 3 \$7.95 US £5.50 UK	<input type="checkbox"/> No. 8 \$6.95 US £5.00 UK
<input type="checkbox"/> No. 4 \$7.95 US £5.50 UK	<input type="checkbox"/> No. 9 \$5.95 US £4.25 UK
<input type="checkbox"/> No. 5 \$7.95 US £5.50 UK	<input type="checkbox"/> Lifetime Subscription \$200.00

I wish to contribute _____ to support
strange phenomena research & investigation.

Subscription renewal Payment enclosed **Total** _____

Charge my Visa MasterCard _____
Card # _____ Exp. Date _____

Name _____

Address _____

City/State _____ Zip _____

Telephone (____) _____

Prices subject to change without notice

All prices include US & UK postage. Prepayment or credit card only. Back issues cannot be purchased as part of a subscription. Allow six weeks for delivery.

Foreign subscribers: please send US funds only, drawn on a US bank and include \$1.00 additional postage for each back issue. • UK subscribers: make check in sterling out to "Mark Chorvinsky."

Send to:
Strange Magazine
PO Box 2246, Rockville, MD 20847

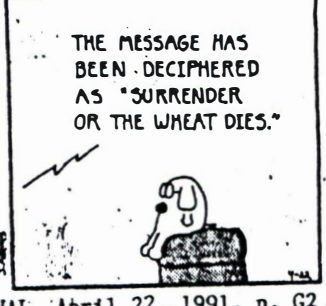
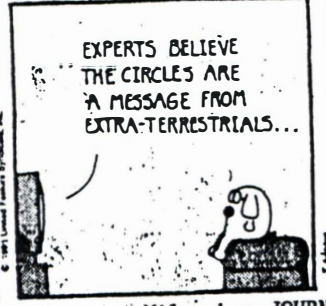
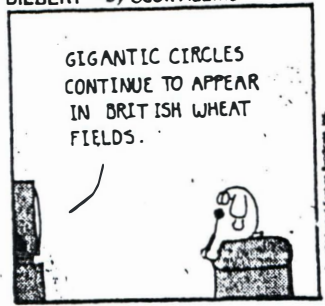

Milwaukee JOURNAL, April 22, 1991, p. G2

Milwaukee JOURNAL, April 23, 1991, p. G2

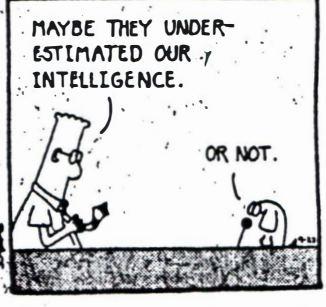
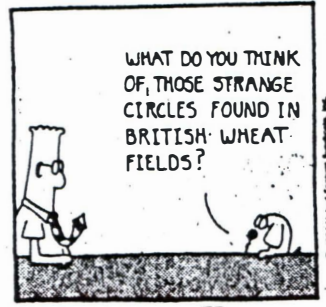

Milwaukee JOURNAL, April 24, 1991, p. G2



Milwaukee JOURNAL, April 25, 1991, p. G2



Milwaukee JOURNAL, April 26, 1991, p. G2

5 (last installment in this episode)



The following very questionable case appeared in "The Missing Link", December 1991 issue, Number 111, 3001 S. 288th, Suite 304, Federal Way, WA, 98003

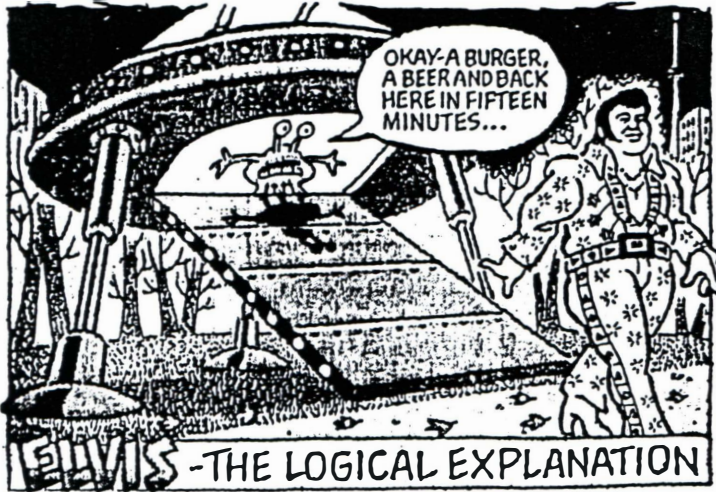

SUNtoon ©BY JIM PHILLIPS



CHUBB & CHAUNCEY



BROOM HILDA

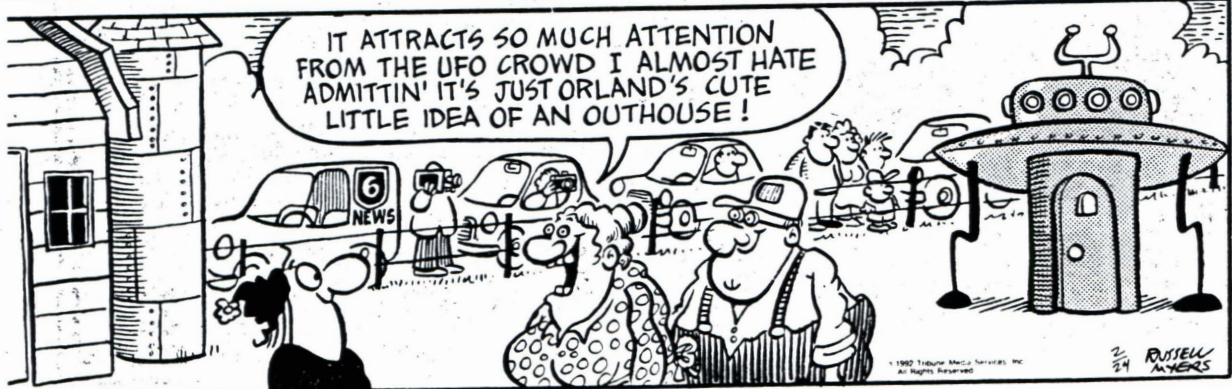

SWEDISH ABDUCTION AND CONTACT



SWEDISH ABDUCTION AND CONTACT

Dreams or alien contacts?

By Clas Svahn

For more than six years Ante Jonsson, 47, resident of the small town of Tingsryd in the Swedish county of Smaland, has had contacts with aliens from another world. Ante Jonsson has produced hundreds of pages filled with notes from alleged travels to other planets, enigmatic prophecies, warnings and an innocent love affair.

Starting out as a rather ordinary observation of an UFO at 1 a.m. on February 3, 1984, the encounter soon developed into something that was to change Ante Jonsson's life completely. This encounter will be described, in detail, later in this article.

To make a brief summary of this highly complicated case creates some problems. Especially since the contacts continue even as I write this article. Ante, himself, is not sure of what is going on around and inside of him. It could be dreams, he says, but doubts his own conclusion.

Although AFU is only at the beginning of investigating this case, there can be no question that something real triggers the events, i.e., journeys to other "planets" and some kind of altered states communication, which have followed on the first encounter.

The main question, however, must be to find out if Ante Jonsson's contacts and travels to distant places are to be considered as "real" in a nuts-and-bolts-sense or if it should be viewed as a part of some highly complex inner trauma.

Several articles have been published on the case in Swedish newspapers, local radio stations have interviewed him, and in 1989 Ante published a book about his experiences in cooperation with a retired teacher from Sundsvall, Sune Hjorth. The book (published in Swedish only) was Hjorth's first involvement with the UFO problem. In spite of all this publicity, the encounters are as mysterious and unexplained as they were in 1984.

What makes this case complicated is not only the recurrent "dreams", where Ante is able to meet his woman contact "Jenny", and to travel to other places in the universe. Even the very first, and most concrete encounter, seems to be as hard to grip as any "dream".

To label Ante Jonssons experiences "dreams" is not really fair. A dream is something everyone can look forward to having in bed and in the night, but Ante experiences his "dreams" outside of his home.

He can feel when a new contact is coming up, several days ahead, and when the time has come he usually drives his car to a nearby lake where the contact is made.

There seems, however, to be circumstantial evidence that he is going through some kind of altered state, entering a "dreamland" or another dimension, where his contacts can be made.

THE INITIAL EXPERIENCE

With the help of Antes own account of his experiences, a written police report, and a case record from the hospital in Vaxjo, AFU can now give a concise picture of what really happened on the night of the 3 February 1984. The night when everything started.

This night Ante Jonsson was driving south on Road 30 from Ingelstad to his home in Tingsryd. It was snowing and the road was slippery. Ante slowed his car down as he approached an area where he knew there could be moose. Soon he caught a glimpse of a small figure by the left side of the road. Further out on a meadow he could see a huge, black object hovering in the air. Astonished and curious, Ante stopped the car to watch for the small figure, but couldn't see him.

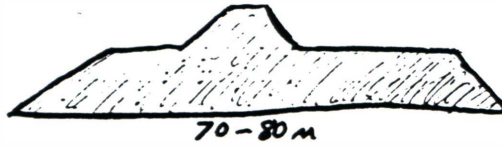

My first thought was to go and get my camera, which I kept at home, and return to take a picture of the craft out in the field, Ante told AFU researchers during an interview in March 1990. I stepped on the accelerator and headed home.

When Ante returned to the site the time was around 1:30a.m. The craft, which had looked like "a flying submarine", was gone so Ante decided to drive another kilometer and then turn at a roadcrossing.

Reaching the crossing he suddenly spotted the object again. It was now blocking the road. He brakes to avoid a collision with the black craft but the car skids and stops with the headlights on the mysterious craft. In an attempt to flee, the car got stuck in the snow on the roadside.



STRUGGLE WITH CREATURES

When I opened the door and tried to get out I was caught by a creature that grabbed my arm and nearly lifted me out of the car. I screamed as much as I could.

Ante managed to strike himself free and started to run, but was soon caught once again. This time his struggle was to no avail and he lost consciousness. Before fainting he caught a glimpse of his body being dragged towards the craft. He could also spot a truck passing by.

As I woke up I found myself sitting in the car again; cold, wet and with a stinging feeling in my hands. I also have a brief memory of talking to someone, whom I later found out was a police officer. After that, all I remember is waking up at the hospital in Vaxjo.

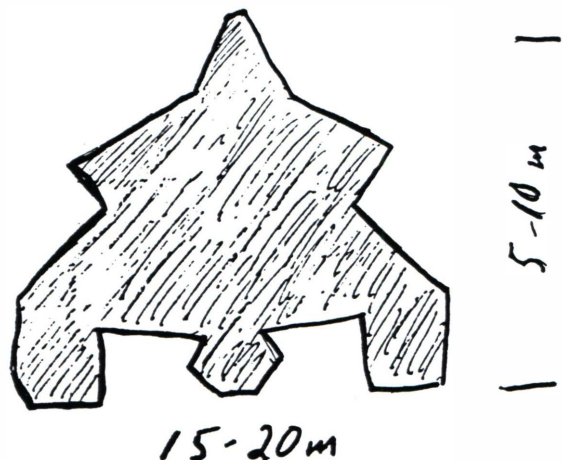

The policeman, which Ante referred to, was called to the scene in the company of a colleague, after a mysterious phone call had been received at the police station. The call was from a man calling himself "Bengt Johansson from Kristianstad". This "Bengt Johansson" stated, according to the filed police report, that he had seen a car with its lights turned off standing on the road and, quoting the text, "with a black object hovering over it".

"Bengt Johansson" was driving southwards from Vaxjo, heading for Tingsryd, when he spotted the car and the object. According to the report "Johansson" got scared and headed back north until he found a phone booth from where he made his call.

But the police patrol from Vaxjo never found "Bengt Johansson" and in spite of a quite thorough search neither has AFU researchers. This implies that the name is fake. But who did the call? Was it the truck driver that Ante remembers passing by? Or was it somebody else?

FINGERS BENT LIKE CLAWS

Whoever it was, the scene had changed as the two policemen arrived at Ante's car. The object had vanished. In the car Ante was sitting, frightened and confused. He was trembling and the policemen couldn't get in contact with him.

The report also states that "the muscles in his arms and hands were very tense and the fingers bent like claws". The policemen decided to take Ante to the Vaxjo medical clinic where they arrived ten minutes to three in the morning.

At the hospital, the doctor promptly concluded that Ante suffered from a severe shock, hyperventilated and had a staring look. The doctor also noticed, as the policemen had, that ante's fingers were bent in cramp. He gave Ante an injection of valium, a sedative and tried to make contact with the patient.

Ante had great difficulties to communicate and spoke only briefly to the doctor. In response to the question if he had experienced something terrible Ante answered with a short "yes."

When the doctor considered Ante fit for moving, he was transferred by ambulance to the psychiatric ward at Sankt Sigfrid's hospital in Vaxjo where he had to remain for a couple of days - a stay which Ante describes as one long scene from the movie "Flying over the cuckoo's nest".

This far the vital parts of Antes story can be validated with documents from the police and the hospital. It is without question that Ante Jonsson has been exposed to something very frightening near the road where he was found. To simulate the medical signs, the cramps and the shock, both acknowledged by the police and doctor, would be nearly impossible. The cramps imply that Ante held on to something very hard, most probably the steering wheel.

But the main question remains unsolved: what did Ante Jonsson encounter on the road in the middle of the night seven years ago? And what made him so afraid?

ABDUCTION STORY

Ante himself asserts that he was abducted and taken on board the large craft by some aliens. This information was given to him in the summer of 1986, two and a half years after the scary meeting.

In a conversation with Jenny (his contact and "supervisor" from another world), minutely recorded by Ante, he was told how he was in such a deep shock that he was carried aboard the submarine-like vehicle. For a moment the aliens feared he was going to die since his heart nearly stopped.

To save his life, Jenny told him, he was placed inside some sort of pressure chamber with bands covering his waist and breast. The rescue operation was successful and Ante released.

According to Jenny the crew took some samples of Ante's hair to "measure his total lifespan"; previous incarnations included. They also took a sample from his skin to determine his physical and mental condition. When all this was completed Ante was released and taken back to his car, since another driver nearly discovered them.

So far this is Ante's own account of what happened aboard the craft. But this was only the beginning of a series of strange encounters, meetings and travels that were to change the life of Ante Jonsson completely. This we shall look further into, later on.

ENIGMATIC INFORMATION

Strangely enough, it is not only the travels and "dreams" that are hard to comprehend and explain. Even the very first, and most tangible, parts of the story such as the actions reported by the police on the night of February 3, cause problems for a researcher.

For some unknown reason the two policemen altered their story as time went by. They state that they found a lens case outside the car (Ante says that he never owned such a case), and that they locked up the car as they left the site to bring Ante to the hospital (Ante says that the car was impossible to lock due to a malfunction). Why these details, insignificant as they seem are distorted, is hard to understand.

Interest from the police did not stop with this first intervention. The same day as Ante Jonsson was able to leave the hospital of Sankt Sigfrid he was approached by the Criminal Investigation Department of the police in Vaxjo. For over an hour he was interrogated on the scene, and every detail was measured and drawn by the police.

Since the observation occurred near a sensitive military installation this interest is understandable. This may also explain why the police removed the film from Ante's camera and kept it for a long while.

Thus far, everything indicates that Ante has experienced something real and frightening. But what did he really see?

New Contacts

A couple of weeks after the first encounter Ante "feels" a voice calling upon him, trying to make contact. He keeps this feeling to himself. It isn't until the night of the March 6, 1984, that he gets to meet with the aliens again. Ante writes;

"This night I was awakened by somebody touching my shoulder and I got up from my bed. There was nobody in the room except for my sleeping wife. I felt that somebody was calling me and went to the kitchen, now fully dressed, and later out into the street. There I see a man in a long, black coat. I start to walk towards him. He disappears for a moment but soon I can see him again. My God, he has no feet! He floats down the street and as I follow him I can see a very pale and long face looking at me."

After a short walk Ante finds himself at a nearby meadow where a black craft is hovering. The pale man is standing in front of it and then he disappears. Ante can see the craft moving towards him until it is right above him.

"It hovers for a while and then something incredible takes place. I feel myself floating in the air but I can't feel any sensations. A moment later I am back in the garden outside my house.

FIRST UFO RIDE?

His next meeting was not until nearly two months later, on April 26, 1984. On this occasion he is taken on board.

"I find myself in a room that looks like a big crystal ball. I can feel someone else in the room but as I look around there is no one to be seen. Outside the crystal I can see the ground far below."

Ante finds a bench on which he sits down. The bench is soft and feels like he's sitting in a bathtub. After two hours the black figure from the previous meeting emerges. Ante estimates his length to 160 centimeters, of normal physical structure but with long arms, his hair growing all over his face. Ante can see no ears no chin. Two black eyes, a flat "nose" and thick, prominent lips makes up the face.

This "man" gives Ante some grayish looking fluid to drink and turns to a board on the wall where a test in Swedish, emerges. Ante gets to know that their conversation will be made by some kind of magnetic thoughts on the board.

During this first trip, Ante is told the usual contactee messages that we are not alone in the universe, and that there are other solar systems with inhabitants of higher intelligence than ours. He is also warned of a coming catastrophe if we keep using atomic energy.

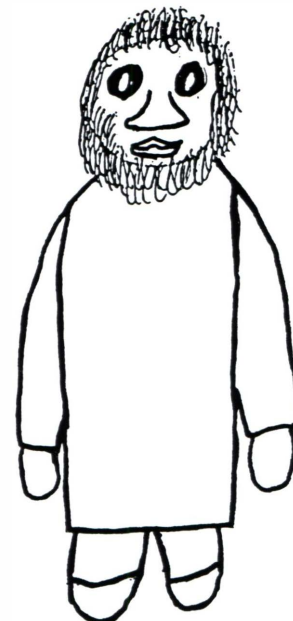

CONTACTS WITH JENNY

This time he didn't meet Jenny, but later on Jenny will be his main contact.

During his trips he has long conversations with Jenny. Subjects differ, from talking about everyday life to nuclear war - of which Ante is not only warned but also given a specific date of when it is going to start. A date he does not want to reveal. He is also taken to a planet devastated by a nuclear holocaust.

He swims, eats and mingles with Jenny's friends in a way that is far away from the often technically complex American abduction scenarios, and seems more like a postcard from a trip to a foreign country.

Since the first event Ante has written several hundred pages about his experiences. When asked where he thinks these travels have taken him he says that he is not sure, but thinks he has been outside our solar system. He has visited three or four different places but refuses to speculate where these may be situated.

In his trips he has come to meet many different human-like creatures. One of which he refers to as "the half-ape", another is called the "fir-eater" and a third one which has a thin body and long arms. And then, of course, Jenny.

LOVE AFFAIR

It is Jenny everything focuses on. She is the cause of all the contacts. Jenny is beautiful, wise and easy to like. Sometimes it is hard for Ante to distinguish her from another girl, on earth, that he once fell in love with. A love affair Ante cannot forget. Jenny is, without any doubt, the key to his "dream-world".

The journeys with Jenny to other worlds are filled with questions. But the answers are often evasive and unclear. During their many conversations he feels that Jenny is avoiding answers, and instead gives him her views and her thoughts. This fact disturbs him. Nevertheless he experiences their conversations as meaningful and very important.

Jenny is as "real" as any living person - at least to Ante. He finds her attractive and strong.

When we discuss his experiences and journeys to other worlds Ante hesitates. He states that he does not know how real his experiences are. Of course, they are real to himself but he cannot say for certain if they are real in a more objective sense. There is no definite way to distinguish them from dreams.

● It can all be a dream. I can't stop thinking that, says Ante. Neither can I stop knowing that it all happens in the real world. Sometimes I don't know what to think.



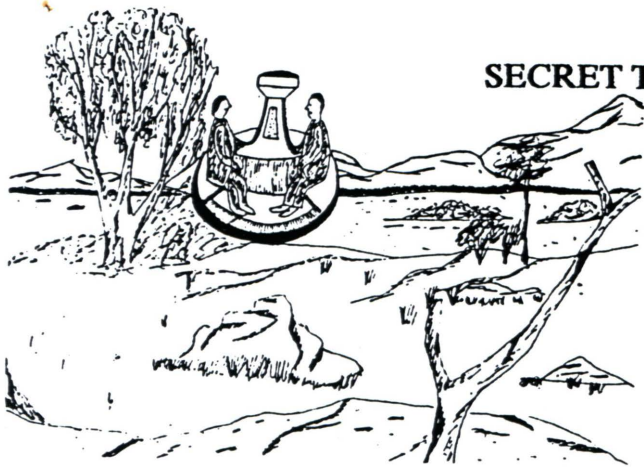

SECRET TO HIS FAMILY

CS: In what way has your family reacted to all this?

AJ: I tried not to tell them and kept it a secret as long as I could. But eventually they learned about it. After finishing the book "Fantastic Journeys with UFO Visits to Other Civilizations", 1989) I had to tell them.. My wife really don't want to know that much and there are many things I haven't told her. We don't talk that much about it.

CS: Her situation must be rather odd, living with someone who lives this kind of double life.

AJ: Yes. I have thought about how I would have reacted if the same thing was happening to her. I would have considered her nuts! That I would have told her. But she takes it all right, which surprises me very much even though her initial reaction was that I was going crazy. She never said that out loud. No, she just told me that maybe it all was a vivid form of dream.

CS: And that was your own opinion for a while...?

AJ: Yes - and it still is. I mean, I am not really sure what is happening to me. Maybe it is a dream, maybe not. But I think not.

CS: Talking to you in 1986 you called everything "dreams".

AJ: Some of these things I experience I still consider dreams. But I'd rather keep it all an open question. I really don't know what is going on. You know, when this thing happens nothing else exists around me. It is a mixed feeling between reality and something else.

ADVANCED WARNING

CS: Your perception of the world around you changes?

AJ: Yes, in some way. And this can happen anytime, day or night. But most of the time it happens at dusk.

CS: Can you describe your reaction when you are being contacted?

AJ: I feel restless and all my body gets a creeping sensation. I can't find the words to explain it. Something starts to move inside of me. In my body and in my head. And when this is happening I know that something is going on. One to three days later I have a contact.

CS: Does this creeping sensation stay until you get the contact?

AJ: No, it passes away. I only feel it for a day or so. Then, suddenly, after another day without the feeling, it all happens. There is no such feeling during the contact, nor afterwards.

CS: Does this change of reality hit you gradually or is it an immediate sensation?

AJ: It comes very quickly, often when I am looking at the TV. It always begins between my toes and moves upwards, as if somebody was stroking your leg gently with a hand. When this feeling reaches my breast I really know that something is going to happen. But it always begins between the toes. It sounds strange but this is true.

In this way Ante is always warned in advance that a contact is going to be made. When he feels that the right time has come he tells his family that he is going for a ride in the car, but never reveals his true destination: a lake ten miles to the north. At this lake most of the contacts have been made.

TIME DISTURBANCES

Reaching this lake he sits by the shore, waiting. A couple of hundred meters behind him cars pass by on the busy road between Tingsryd and Vaxjo (the same road where he made his first contact). No one seems to pay any attention to the egg-shaped craft hanging over the lake. Except for Ante himself.

The craft, hovering in front of Ante, descends and Ante is taken on board. After a short trip they return to the lake but this time everything has changed. On one occasion Ante told me that it was as if he had been taken back in time. The road and the busy cars were gone, the fields and trees looked different. On another occasion he left a winter landscape for a hot summer's day. But never has he travelled to the future.

The first year or so, he was taken to other places as well. Places far away, at least Ante thinks so, maybe to other planets as we have seen before. Inside the ship he has met other human beings, from other countries, all travelling to distant locations by their own free will.

Today Ante keeps three different files on what is happening to him. Hundreds of pages are filled with his notes. I have only read a part of them since he chooses to keep most of it hidden in a safe-deposit box at a bank.

The first file concerns his journeys and conversations with Jenny. The second is information on previous lives, revealed to him through automatic writing. And the third is all about himself, memories from his life as a teenager. And these memories are often very bright, sometimes painful.

THERAPY

When I asked Ante about his feelings when writing about his youth it is clear that this is very important to him. There are memories that he would rather not tell about. Writing them down is a relief to him, some kind of therapy and he describes the information he gets as "memories emerging from within, surfacing for him to write down".

CS: Do you feel that this is some sort of therapy given to you by Jenny?

AJ: Yes, it seems so. Here I am confronted with things I haven't been aware of for a long time.

Can it be that this is what it's all about? That this therapy is the climax and purpose of the whole experience? Maybe all that has transpired is a mere framework leading to Ante's inner self, giving him a chance to deal with his traumas and hidden memories? This is not an easy question.

As with any other contact story, Ante's has two faces. Some of them much more tangible than some obscure memories from days past.

ARTIFACTS

During one of our conversations Ante showed me a stone that he once found in his pocket after one of the trips from the lake. It wasn't big and not very unusual. When I held it in my hand it felt smooth and nice to touch. An ordinary stone as far as I could tell.

Ante says it resembles the stones he had seen on the shore during one trip to the "summer lake". He and Jenny had been taking a swim and afterwards they had been sitting on some stones by the side of the lake.

Maybe Jenny put it in his pocket, maybe it just fell in there - or maybe it is just an ordinary stone from this world. As always Ante hesitates and draws no simple conclusions.

The stone has never been analyzed and I doubt that such an inspection would shed any light on its origin. Artifacts from UFO encounters tends to be no better proof than the witnesses own stories.

A grayish, milk-like, drink was given him on yet another occasion. This time he found a plastic looking bottle standing near his home. The bottle contained the same substance. He was supposed to drink it for a couple of days, preparing, as he had been told, for another, longer journey. It seems that the drink was important for Ante's body before making this longer trip. The bottle was later destroyed by Ante and thrown away.

UNDERWATER BASE

Ante states that he has visited an underwater base where he saw huge doors in a cliff. The doors were numbered with ordinary Arabian numbers but the numbers had small hooks making them look like the astrological signs. Never has he reported seeing any unusual writings that he has not been able to read.



There have been some signs on board the ships, however, which he has not been able to decipher. One of them, frequently used on some boxes, looks like the sign of Pisces but with its two arches intersected. It sounds strange but it is true, states Ante.

NEW YORK EPISODE

One evening, the 20th of October 1986, he is taken to a big city where he later meets a girl and eats a meal with her. The "contact" began as a colored cloud suddenly filled the room where Ante was resting on a bed. For a short while everything turned black. Seconds later he found himself sitting on a bench in a park. Around him big houses point to the sky and he presumes that this must be New York.

There is no room for discussing this mysterious event in detail here but one interesting thing must be noted. Returning home again (Ante found himself standing on the lawn outside his house at 04.16 in the morning, seven hours after the cloud came into the room), he receives a postcard from New York, addressed to "Ante Johansson", postmarked 20th October 1986. The message on the postcard is impossible to read. The meaning behind the postcard is obscure, to say the least.

The New York episode is but another strange coincidence of which this case is filled.

HIDDEN YOUTH TRAUMA

One of the most recent episodes happened inside Antes home when he was looking at a video recording earlier this year:

I was looking at this old black and white film when suddenly I got the feeling of being someplace I couldn't recognize, says Ante. The TV set looked completely different. I got worried and started to walk down the stairs to the kitchen. On my way down I passed by a mirror and caught a glimpse of myself.

What I saw scared me. There I was, looking at myself precisely as I looked like when I was 15! My clothes looked different and I was young again. I went to the kitchen, which I didn't recognize, and had some water.

As Ante "woke up" he realized that what he had seen was himself not only being young again, but also in his old house where he had grown up. The TV set and the kitchen all looked like the things he remembered from 30 years ago.

And this is only one of many examples of connections to Ante's boyhood. The notes he makes all deal with his being 15, 16 or 17 years old. Here a trauma, not yet unearthed, may be hidden.

As many other contactees Ante's experiences are only for himself. There are no witnesses. I know of one occasion when Ante brought two friends with him to the lake after getting the "feeling" in his body. This time nothing happened.

Our research into the case continues. This summary above is only a small part of the story thus far. In our investigation we must be very cautious and open minded. Many of its aspects are still hidden in a safe deposit box by Ante himself. Some other materials are not yet to be published. Until we have seen all the material I will postpone any conclusive judgement.

M A T R I X I I I

Valerian, Valdamar. *MATRIX III: THE PSYCHO-SOCIAL, CHEMICAL, BIOLOGICAL AND ELECTRONIC MANIPULATION OF HUMAN CONSCIOUSNESS*. First Edition. LEADING EDGE RESEARCH GROUP, 1992, 8 1/2 x 11, Velo-Binding, 780+ pages, 1341 line-item index, with Introduction by Michael Topper. This book goes into precise detail on how the consciousness of human beings is being modified by psychological and social institutions, specific chemicals added to the food, water, and environment, and how the tactical aspects of chemical, biological and electromagnetic warfare are being implemented in order to support the aims of the planetary power structure known as the New World Order. The book begins with a section familiarizing the reader with basic scientific information about resonance, oscillation vibration and frequency, and moves rapidly into discussions about human auric band structures, frequencies, and telepathic interaction. *MATRIX III* discusses all the aspects of the natural electromagnetic fields of the earth, holographic aspects of the universe and consciousness, morphological fields, hard-to find data on the human brain and neurophysiology, brain structures and consciousness, and brain circuitry as applied to human consciousness and behavior. Psychosocial aspects of human society are discussed in detail, with emphasis on belief systems, perception, the triune functions of security, sensation and power in human society, four separate levels of social manipulation, including detailed data on consciousness, genetics, manipulations of humans outside of the physical realm and beyond. The use of specific substances in the food and water is discussed in great detail, with emphasis on effects and intent. If you live in this society today, this book is a must-have item. The elements of population control through the use of biological organisms is discussed, all the way from the very concept of disease to the covert production of biological weapons under the guise of various government programs. Incredible data. There is more information on disease in this book than you will ever find anywhere else; much information in this book has been gleaned from Freedom of Information requests. Sections on biological warfare, the immune system, immunizations and vaccinations, neural fungi, zoonotic diseases and veterinary biology, viruses (both human and extra-human), and revealing data on who runs the major drug and chemical companies and how it is all connected; the section on electronic mind control in this book has no equal, going even beyond that done in *MATRIX II*. *MATRIX III* discusses the very groundwork of electromagnetic spectrum use, the deliberate suppression of data (which is revealed) that could have completely changed the planet, a host of data on Advanced Mind Control Applications that goes beyond anything you have ever seen before, in short, everything you always wanted to know about what is going on, including the new electronic networks, use of the cellular telephone system, mind control projects (up-to-date) and manipulations of the earth grid vortices of the earth itself. Interspaced with the material comes a host of data, supplementary material, interviews, and revealing information. The "Final Scenario" is discussed relative to the New World Order and the plans for total economic control, a one-world religion, and the electronic mind control objectives, schools of thought, and research. *MATRIX III* brings out in detail how various families in the United States and Europe are involved in a scenario which has as its main tenet the suppression and elimination of human beings on many levels - a scenario which includes worldwide traffic in drugs, vast laundering of drug money by national banks of several countries, and assassination and murder. These are the people who arranged and supported all the wars. There is discussion of the Bush family, and how Prescott Bush assisted the finance and management of the Nazi empire - the so-called Hitler Project. Perhaps the greatest feature of the book is the material on consciousness which, when combined with the book in a holistic way, has the potential of assisting you toward conscious empowerment and understanding of the drama which is occurring on a vastly higher level. Michael Topper makes an active contribution in a series of articles that catapult the reader into a state of non-dual awareness - a state which is required in order to evaluate the book - and your life. *MATRIX III* is a whole new experience, including much more than can be detailed in this brief review. It is a brand new adventure in consciousness - one from you won't want to return.

MATRIX III is available ONLY from LEADING EDGE RESEARCH, POB 481-MU58, YELM, WASH 98597

\$49.95 PPD - AVAILABLE ON OR ABOUT 1 MAY 1992 - LIMITED PRINTING.

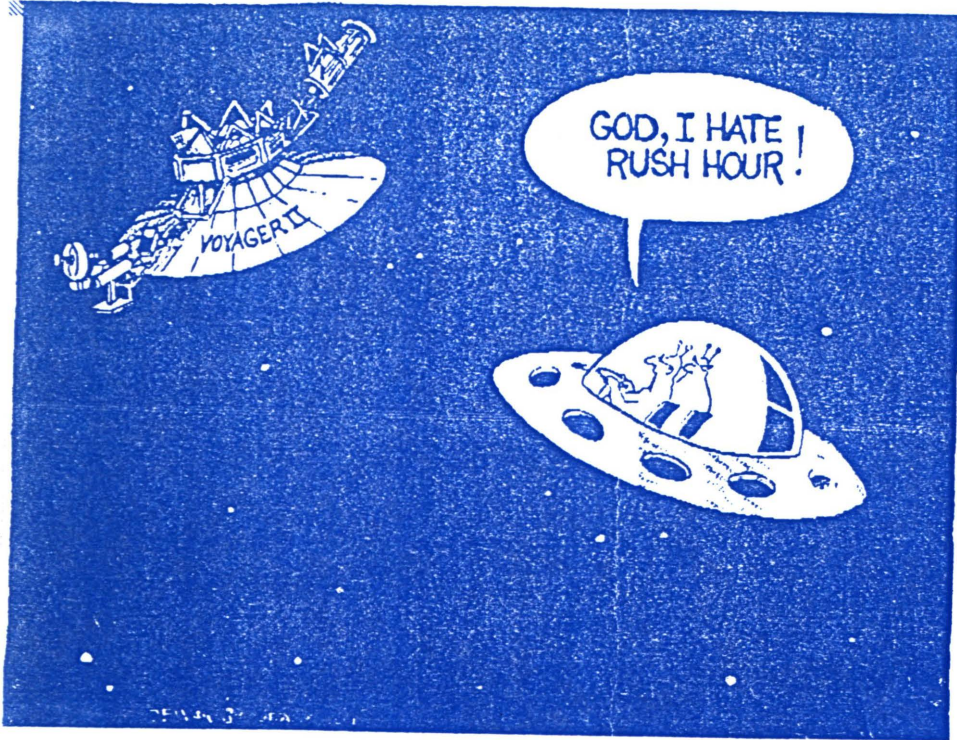

HERMAN®

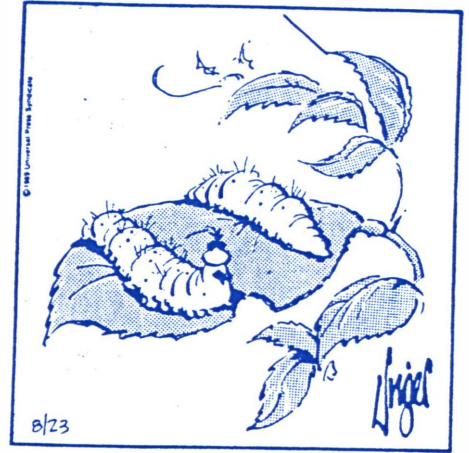

"I wonder if there's intelligent life on other trees."



rior-Mail Brisbane

THE FAR SIDE

By GARY LARSON



"Now wait just a minture here How are we supposed to know you're the REAL Angel of Death?"

Alien Abductions

A new 90-minute video!

Enclosed is \$26.00 (check or money order in U.S. dollars), which includes foreign postage and handling. Please rush me a copy of the new video *Alien Abductions* (VHS only)

Name _____

Address _____

City _____ State _____ Zip _____

Send to: The Center for UFO Studies
2457 West Peterson, Chicago, IL 60659

Historic footage and eyewitness interviews with abductees like Betty and Barney Hill.

Plus opinions of such experts as Budd Hopkins, author of *Intruders*

Walter Webb, astronomer at the Boston Planetarium

Mark Rodeghier, scientific director of CUFOs

Michael Swords, editor of the *Journal of UFO Studies*

\$26.00 includes postage and handling.

Order today!



JUST PUBLISHED!

JOURNAL OF UFO STUDIES

New Series, Vol. 3

1991

CONTENTS

ARTICLES

- *Folkloric Dimensions of the UFO Phenomenon Thomas E. Bullard
- *Psychosocial Characteristics of Abductees: Results from the CUFOS Abduction Project Mark Rodeghier, Jeff Goodpaster & Sandra Blatterbauer
- *Double Abduction Case: Correlation of Hypnosis Data John S. Carpenter

RESEARCH NOTE: DELPHOS, KANSAS, SOIL ANALYSIS

- *Introduction Michael D. Swords
- *Soil Analysis Results compiled by Michael D. Swords
- *Further Comment on the Delphos Data Erol Faruk

COMMENTS AND RESPONSES

- *Malcolm Johnston, *Mark Rodeghier, *Robert A. Baker, *Kenneth Ring, *Hilary Evans, *David M. Jacobs, *John P. Wilson, *David A. Gotlib, *Martin Gottschall, *Keith Basterfield

BOOK REVIEW

- **The Report on Unidentified Flying Objects*, by Edward J. Ruppelt
..... reviewed by JUFOS editor Michael D. Swords

183 pages

YES!

SEND ME A COPY OF VOLUME 3 (1991) OF THE JOURNAL OF UFO STUDIES FOR \$21.00
(CHECK OR MONEY ORDER IN U.S. DOLLARS), WHICH INCLUDES FOREIGN POSTAGE & HANDLING).

NAME _____

ADDRESS _____

CITY _____ STATE _____ ZIP _____

PLEASE MAIL YOUR USD CHECK OR MONEY ORDER ALONG WITH YOUR NAME AND ADDRESS TO:

THE J. ALLEN HYNEK CENTER FOR UFO STUDIES

2457 West Peterson

Chicago, Illinois 60659

(C) '92
All rights
reserved



-- HEADQUARTERS --

U F O R I C

U.F.O Research Institute of Canada

Phone: (604) 685-1UFO

DATE : 1992

BY LORNE GOLDFADER

"ABDUCTION ACCOUNT"

Alvina Scott is a soft spoken and very modest lady in her thirties who resides in the coastal city of Vancouver. To the best of her conscious recollection she had a series of direct encounters with aliens beginning in 1985. During that year, Alvina was living on the outskirts of the city in a populated area only a few hundred feet from a hydroelectric power substation on the ground floor of a three level apartment building. A small craft landed in the back alley near her window two hours before sunrise. Mass autosuggestion was apparently used on drivers in the area not to park their cars close by, and was used to keep others in a sleep holding pattern so they would not wake up. As she was taken out of the window, Alvina was told that she was being placed into a black limosene. However this automobile "took up two parking spaces and made a whoosing sound".

Alvina had a kidney problem at that time. The pain was so bad and the organ was in such poor shape that her own doctor wanted to remove it. The aliens removed eggs from Alvina telling her that they merely wished to examine them. At a later date she discovered this was not entirely accurate. "They" also performed an operation on her kidney cutting between the cells and leaving no scars. An implant was left inside to ease the pain, which later showed in ultrasound to the astonishment of the medical technician. It later flushed out through the urinary tract and was lost in the toilet. She was led to believe that the visitors were human looking but later discovered they were the so called "GREYS" (large bald craniums, short, large wrap around eyes) who were projecting a telepathic illusion. She was able to recall the events consciously without hypnosis as a result of a traumatic miscarriage.

On the craft Alvina was shown full adult bodies which were grown from a fetal state in four days, floating in tanks. She was told that they were cloned from the occupants for doner compatibility and used for organ transplants. They contained no essence or spirit. Alvina did not feel comfortable with this information. She was told that the visitors were able to prolong their lives this way. During her first encounter she had a discussion with a female who did not understand why we "spill or waste seed and why we polluted our atmosphere". In the second encounter which took place during my investigation, there were other abducted Earth humans both male and female having their eggs and sperm removed. This took place in a much larger vessel in space.

The abductee was shown the products of conception at a time between the two encounters, three children in all. One was human with "a badly mishapen mouth", and the other two appear to have been cloned GREY twins who asked her to teach them everything she knew in case some day they had to live amongst us. She refused to cooperate or acknowledge they belonged to her. After the experiences, Alvina Scott became a part time Christian minister. Her religious beliefs and lifestyle completely changed and she quit eating meat.

U F O R I C

U.F.O Research Institute of Canada
Phone: (604) 685-1UFO

INVESTIGATOR'S CASE REPORT

Canada, like most other countries has it's share of U.F.O. sightings, personal contact and abduction cases. During the last five years, the numbers either overtly reported or uncovered through psychological questioning have risen to **ALARMINGLY HIGH PROPORTIONS**. The calls seem to come to us in waves. I am talking here of genuine cases which have been filtered and sifted through the standard investigative processes.

Alvina Scott's encounters are interesting in that the intelligence behind the phenomenon continued to respond and interact during my research. There are elements of deceit and manipulation here which seem to originate from the "VISITORS", whoever they are in reality. Alvina (who is a part time church minister), myself and the media were led to believe at one point that we may have indeed actually retrieved a hybrid fetus, but pathology analysis of the sample proved otherwise. This may have been an attempt to discredit. A second major encounter took place after my initial interview with Alvina and produced a remarkable scene in a room "as large as an airport hangar" apparently inside a craft. There she met a lady who called herself **RUTHIE BAXTER** and who claimed that she was a missing person from Boston, Massachusetts. This lady was being led into a "divisecion room". I feel that this little bit of alien theatrics was displayed before Alvina to produce fear in her in order to discourage the abductee from speaking publicly. It did indeed produce the desired result, however over time Alvina slowly returned to her senses. Another series of events led to her dismissal as a bank teller. This was a direct result of her public statements in the media regarding her encounters. I consider Alvina a very sincere, honest and brave woman who has absolutely nothing to gain from all of this. Her only reward has been misfortune which has mostly come from her 'fellow' human beings in the form of harassment and ridicule.

I have done everything humanly possible to obtain verification and evidence in this case including computer records police tracing of the supposed missing person with no luck. It is as if someone 'out there' was always one step ahead of this. I am left with a gut feeling that there is at least one group or race of beings who wish to keep their activities a secret at all costs short of physical assault, using every technological means at their disposal, in particular the ability to affect specific neurological functions of the brain which I believe, at this period of our evolutionary development is their trump card and our Achilles' Heel.

As a footnote, I would like to add here, that in other abduction cases we have studied over the last several years, some interesting information has surfaced :

- (1) In approximately forty per cent of the cases there was a family member closely or distantly related to the abductee in the armed forces (land, sea or air). This would be a good subject to incorporate into investigative forms.
- (2) Abductees have often reported to this institute, physical, mental and psychic transformation after their encounters. For example, one gentleman who I know living in British Columbia, clots blood immediately (and

-- HEADQUARTERS --

LORNE GOLDFADER / DIRECTOR

U F O R I C

U.F.O Research Institute of Canada

Phone: (604) 685-1UFO

one in the U.S.A.) and heals major wounds within days baffling attending medical practitioners. I, myself have undergone an extraordinary metamorphosis since an incident in April of 1991, and receive very physical electrical pulsations deep into the muscle fibers of my thighs. The trigger seems to be some kind of biological energy emanating from humans, animals, birds and U.F.O.'s.

- (3) A large number of female abductees claim previous miscarriages (in one case, a total of six!). In some instances when the tubes have been tied, attempts were apparently made by the visitors to impregnate the female.
- (4) Graham Conway, advisor to UFORIC who has been researching the subject of U.F.O.'s for over 43 years notes cases of female abductees who may have met their own hybrid children in the real conscious world of everyday life. The women report for example, a young person who might be in the work place, or a friend of their children as being like one of their own. This goes well beyond the usual motherly instinct, to that of unusually strong maternal bonding feelings.
- (5) Marks and symbols have appeared on some of the bodies of abductees whom both we and others have researched and may possibly be linked to the crop circle pictograms. I have termed them U.B.M.'S (unidentified body markings). Comparative analysis between the two phenomena might prove fruitfull and interesting.

To whom it may concern
 I bought myself a camcorder, determined to film the next UFO's I see. I have gone out into the base, behind my house several times but nothing showed up. This makes me wonder if anything will, even if someone were to come and investigate my sightings. Like I have tried to inspire with my writing of them. It's an old Helicopter base behind my house where they trained pilots during Vietnam.

I believe the reason I've seen so many UFO's over the year is because of my name and it's numerical value's 6,16 Times, 665, 777, 865 based on the alphabet with a corresponding 117

number count and my name can be drawn into many things like a shark and a rabbit.

I've written many people and publication's But seldom hear back from anyone Mainly just thank you note's I guess no one really believe's me if they do, I can only wonder why doesn't more happen like getting published or a dialog on the subject with someone I don't know I do know this it cost me a lot of money to write my letter's Anyway I hope you enjoy my work and will consider publishing what I've done.

Your Friend
Chuck Meschweck

1.

I felt it was important to speak about some of the events that have taken place during my life so according to my recollection here be a few of them

My earliest memory of a UFO was back when I was 9 or 10 years of age My Mother and I were at a drive in picture show in Savannah Highway 80 drive in as a matter of fact long since torn down The movie was a black and white about two dinosaurs and a cave man that had been frozen in ice at sea and thawed out on the beach of this island, dug up on shore by some men anyway I happened to look up thru the windshield of the car up into the night sky When I saw a bright brown dot,

at first. That began to get larger, falling and coming down tho it was hard to say because it was directly over head it was making slight circles or spiraling on its way at the point where it stopped increasing in size it became brighter for a moment, almost orange in color I reckon it was about 50 feet in diameter I am guessing at its dimension's Haven seen three saucers that were about that size at the age of 36 Before it vanished it changed shape as well from round to oval then it became dimmer again to a faint brownish in color I have a benchmark that's oval shape below my left knee anyway I figure

it was a thousand feet up the three saucers I saw were a faint brownish in color too

One bright clear blue day I looked up to find a very beautiful radiant silver ring of light over the road just in front of me I drove on, it seemed to be made of vapor.

I was laying in bed one night feeling very sick When I prayed for help I then began to receive within me a strange and overpowering force that felt like a flood rushing through and filling my whole body Lasting only a moment and then it was gone and I was no longer sick I don't think I ever felt better

to make sure, of what was happening

The first time I was out of body in spirit it went like this I was laying in bed, when I woke up and found that I was paralyzed I couldn't move a muscle or even vocalize all I could do was open my eye's and then very fast I felt myself rise up into a sitting position Except that I was in spirit without my body I started to look back at my body to see if it was there) But before I was able to I went back into my body in an opposite motion then how I came out As soon as my spirit and body joined together I snapped out of it I was no longer paralyzed I could move and speak once more

The second time out of
 body not long after the
 first time I felt a
 presence in the room
 with me a dark unde-
 scribable shape I felt
 as if it reached down and
 lifted me up But all of
 this was so faint, it
 could have been just my
 imagination & speaking
 about the presence I felt
 But I was very aware of
 being out of body in spirit
 anyway it was just like
 the first time except this
 time I started floating
 across the room I then
 willed with all my might
 to return back to my body
 and then I was I regained
 control over myself and
 could move and speak
 again The spirit is identi-
 cal to the body in look's
 (finer matter) There was moon
 light thru the window.

6.

One night I was sitting on my couch when I got this urge to walk out side I went out the house and stood on the drive way and looked up when I saw just above tree level, what I thought at first was a gigantic large round red eye, with a dark pupil in the center of it I looked it over with amazement trying to figure it out and then it took off at a very great burst of speed going over the field in front of the house This was when I lived between Perreola and Marlow Anyway when it went over the field I got a clearer idea of what it was it was a UFO saucer type about 50 feet in diameter it stopped for a split second over the field then proceeded on flying straight out, towards the south

7.

This wasn't long after my
out of body experiences
I believe extraterrestrials
have the means to sep-
arate the spirit from the
body and that what
they did with me

This all happened when
I was around 14 years
old at 19 I joined the
Army, the 82nd Airborne
Division I joined in 1973
and got out three years
later in 76 with an hon-
ourable at the rank of
sergeant My second en-
listment was a Chapter
10 This was in the early
80's Anyway let me get
back to my sighting's
I hope you find it of
interest

In the year 1977 one night, while I was out in the field in back of my house the field once being a helicopter base with air strips, that are still there anyway I saw a small soft light like lightning moving at a very fast rate of speed slightly changing it's direction several times yet appearing like lightning in it's course was as it looked to me to be falling down but heading in a due easterly way and then again after a little while starting from almost if not the same place a light much like the one before except this time going upward's toward's a westerly direction according to how I observed it from the road out in the field I also saw two dot's of light at a distance

that might have been two orange spheres. They were traveling slow one behind the other, are on the other hand two saucer's with theirs undersides turned toward me.

A third meteor identical to the other two, that I saw before on different night's streaked across the sky due north traveling along the same path in space appearing at the same time at night as well I also saw this night are early morning many light's moving at a tremendous speed forming curves are curls that at time's seemed to peel off from various different stair's as if they the stair's

where falling this could have been caused by space craft's making quick maneuvers with they're hull's illuminated This might help to explain what I saw before concerning the lightning on account of similarity's in they're appearance And a bright flash of light went off no more then 10 feet from me And there was a meteor shower

In the year 1977 right after Christmas a star shaped object was seen it was reported in the Javan-nah new's paper I did not get to see it I was gone away for a time One night I saw what looked like meteor's up as more of them all of different light magnitudes from soft to very bright like star's

Falling along the same path
in space one right behind the
other yet they were leaving
no traces tail like the two
orange spheres and traveling
just as slow

After all this one night
while I was laying in bed
I heard classical music
inside my head and a
song sung by a female I
can't remember any of the
word's to the song Everytime
I tried to concentrate on
learning the word's to it
it would become scrambled
all I could do was lay back
and more or less surrender
to all that I heard it all
sort of went in one ear and
then out the other Nothing
of it would stick in my mind
Even tho I tried to retain it
to memory all I do know is
that it was a very peaceful

song that made me feel good
 it was a song about a heavenly
 place and peace, that's all I
 know

It looked
 like this
 20' dia.

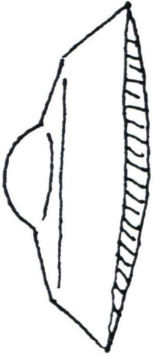

I believe it was in 1975 while
 I was at Myrtle Beach South
 Carolina that I saw another
 UFO in broad daylight this
 time it was just cruising along
 it was year later that I
 learned many people around
 this time saw the same kind
 it was about 250 feet up above
 the ground and 750 feet
 from where I was standing it
 was saucer type approx. 20
 feet in diameter

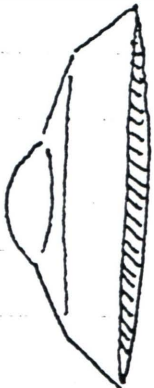

One night while I was in
 bed more than half awake
 I suddenly felt as if I was
 some where else walking
 down a hallway when two
 female's came up to me
 one carrying a writing
 tablet, she had light
 colored hair the other

her hair was dark the blond said I can help you with this she then hit me over the head with the note book I felt it strike my forehead as I was laying back in my bed all of a sudden there. No longer in the hallway with the two women I do believe I was temporarily connected with some other person at this time

Getting back to the night I saw a soft light performing like lightning I also heard sounds like a computer and the voices of a man and woman. Their voices sounded as if it were on a record set to slow speed I couldn't understand what they were saying I had to enter a state of meditation to hear this

I started with a pen size hole on a round piece of folder paper, cut

that way by me anyway
no matter the few
are six times around
within cutting with
scissors the hole stayed
the same size they have
a mastery over matter.

I found a lens, sort
of like a cheap jeweler's
scope, at an isolated
dump, the lens being
a magnifying glass that
may have been a true
means they the higher
state can communicate
with us through I
picked up several pic-
tures, one was that of
Darth Vader of Star
Wars fame Unfortun-
ately it was stolen and
took back? and only I
knew of its special
quality it worked in
conjunction with a flash
light, beamed thru the

Sense on To paper

Jan 1990 a further sighting appearing out of no where, (are so it seemed) In front of a small star, that was at the horizon, due east I saw three flying saucer's one right after the other, one at a time about a minute apart from each other, it may have been one ship making an appearance three times. They were approximately 50 feet in diameter looking a little bit phantomyish because they're hull's were dimly lit a faint brownish in color. This clearly visible to the eye in the dark night sky. They were about 750 feet up in the air and 1200 feet from where I stood.

traveling at a slow clip
 of speed accelerating away
 from the star on a flight
 line that was crossway of
 me then they would vanish
 out of sight I also saw a
 little later on around mid-
 night a large red ship, who's
 hull was dimly lit too
 shaped like a walnut flying
 in a fog bank, very slowly
 towards the city of Yavan-
 nah I saw this after what
 may have been a commer-
 cial or military airplane
 it sounded like it was pro-
 pelled by prop, that flew
 low over head it was too
 dark to see the fuselage
 By the way I took aircraft
 identification in service

I'm always alone when I
 have sighting's I would
 like to try and see more
 with other's present to

⇒

except for no more thing

witness everything as well
 But with a warning right-
 ing like I have because
 of my name can cause
 Depression the way it has
 with me I don't guaranty
 anyone will see anything
 anyway I may end up look-
 ing like a bigger fool then
 how I already feel sometime's
 until I see something new
 that is

This conclude's all what
 has happened to me invol-
 ving extraterrestrial's are
 angel's I don't know. When
 I think to myself I pic-
 ture many different crea-
 tion's up there I hope we
 are friend's no matter
 what they be there's not a
 day that goes by that I
 don't think of them and
 wonder what all it could
 mean like one day us
 living together it could
 happen tomorrow are

not at all in my life
time

P. J. The night I saw
these saucer I also
saw before them a
small bolt of light -
ning at a distance to
the east that was an
odd brown in color and
it made no rumbling
sound or thunder I
thought it was very
strange there is another
field about where it
appeared about two
miles away to the east

If you would like to
see more of my drawings
send \$20.00 (American currency)
(current)



8/2



248

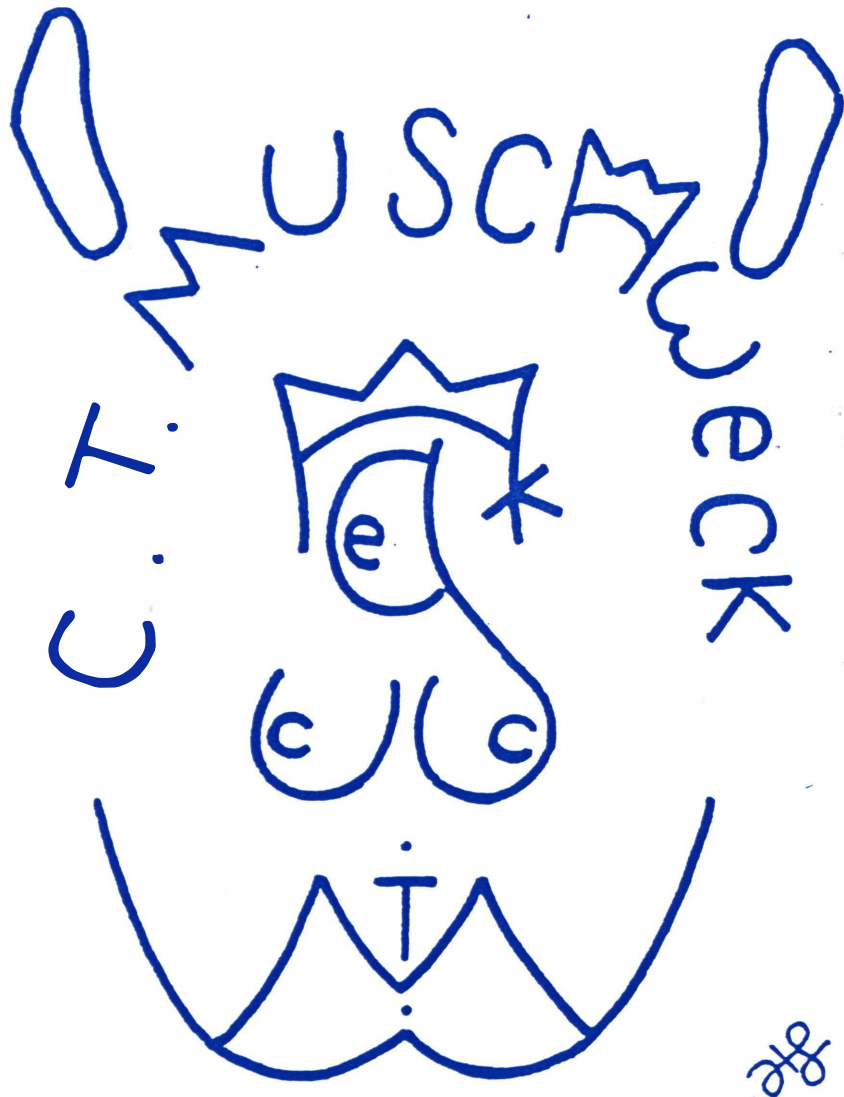

PERPETUAL MOTION DEVICE Magnetic Motor

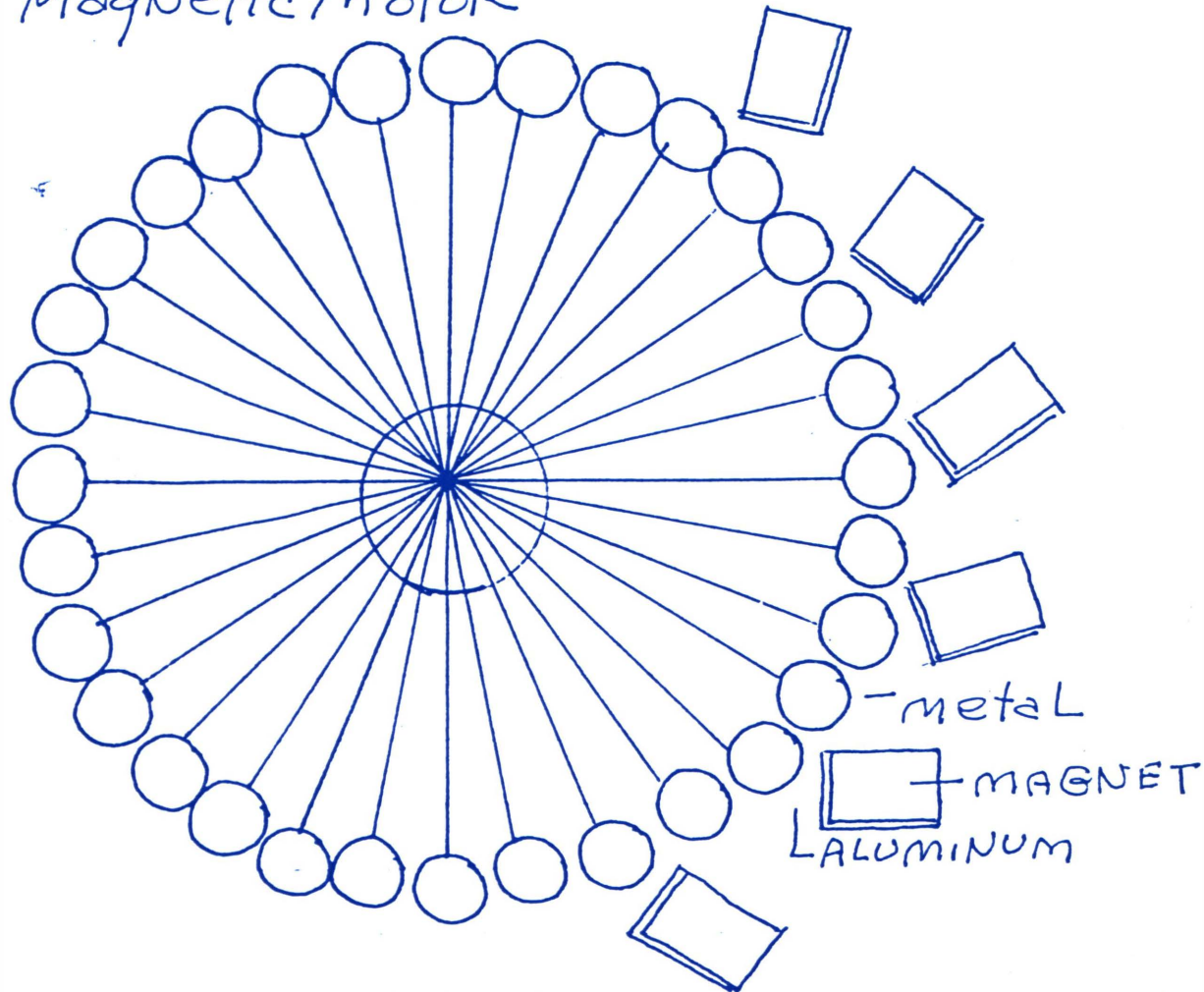

Magnets are slight'ly cocked toward'z oncoming metal spheres aluminum is tin can thin fitted snug to magnet Purpose to turn electric generator to produce electrical power Don't know if it work'z are not Another way is drawn below

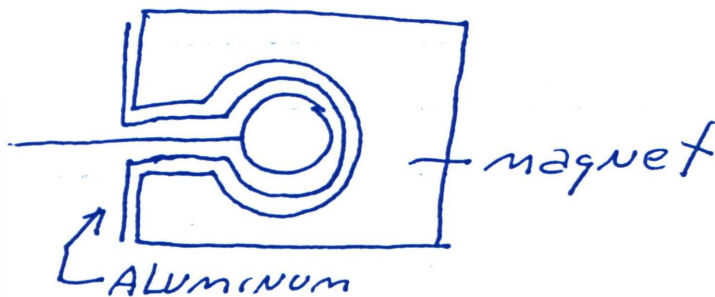

MAGNETIC - MOTOR

An idea? it will work if major gear will turn smaller gear's!

8-28-89
8-29-89
1:09 AM

Disregard larger gear. Center gear may need to be bigger with two smaller gear's (to create fulcrum) to rotate magnet's counter clockwise

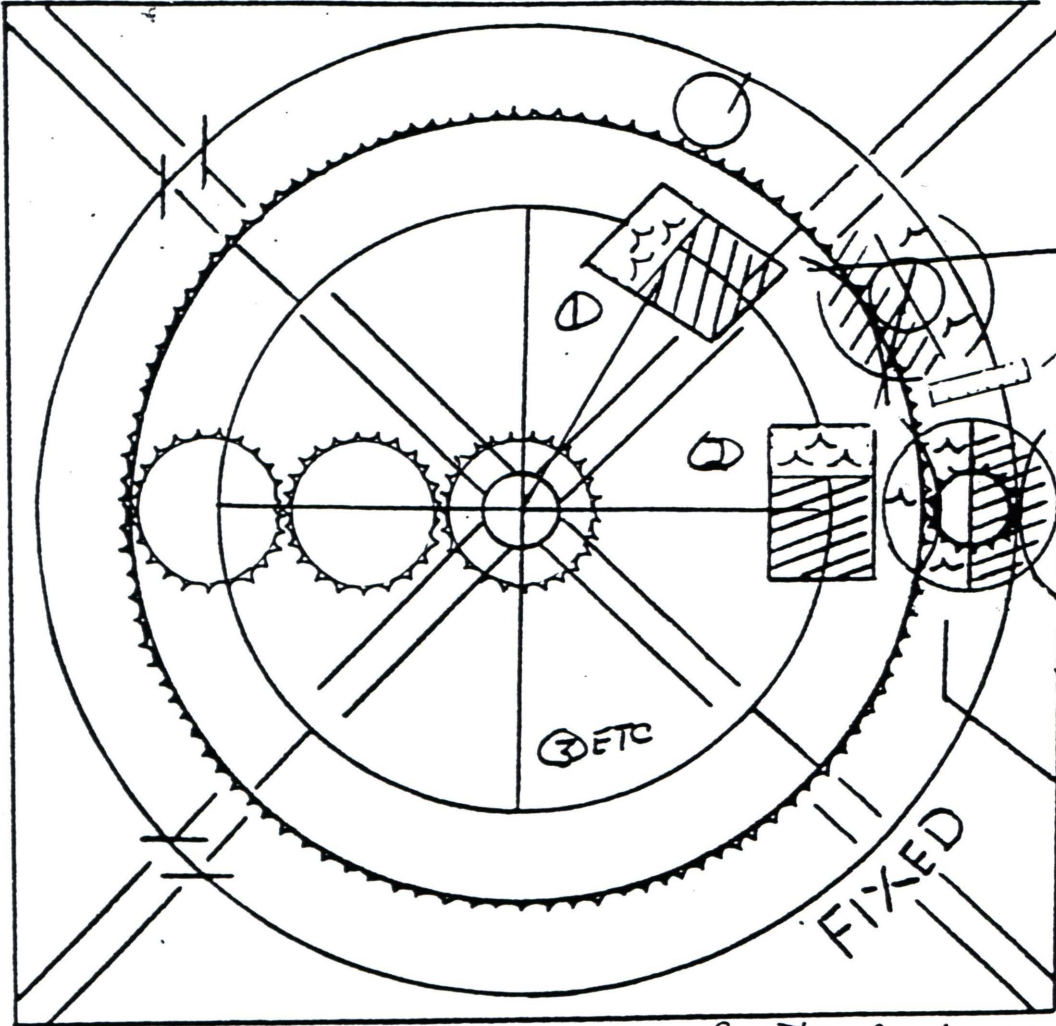

May not need H₂O block's for different distance's in rotation's
Instead of H₂O Block Aluminum Tin Can thin curved around
Purpose To Turn electric magnet generator or power novelty bottom stem. Electric automobile's on right side

1:18 AM

Looking for partner's 50-50 Can't build this myself to test But I believe it might work all aluminum except for magnet's (12 of them) and metal weight's (6 of them)

Charles F. Muchweck
Rt#2 Box 365
Houston Georgia 31312
side
top
left
side

I added aluminum block between magnet's

PERPETUAL MOTION DEVICE

I don't know whether or not they work?
 Looking for partner's 50-50

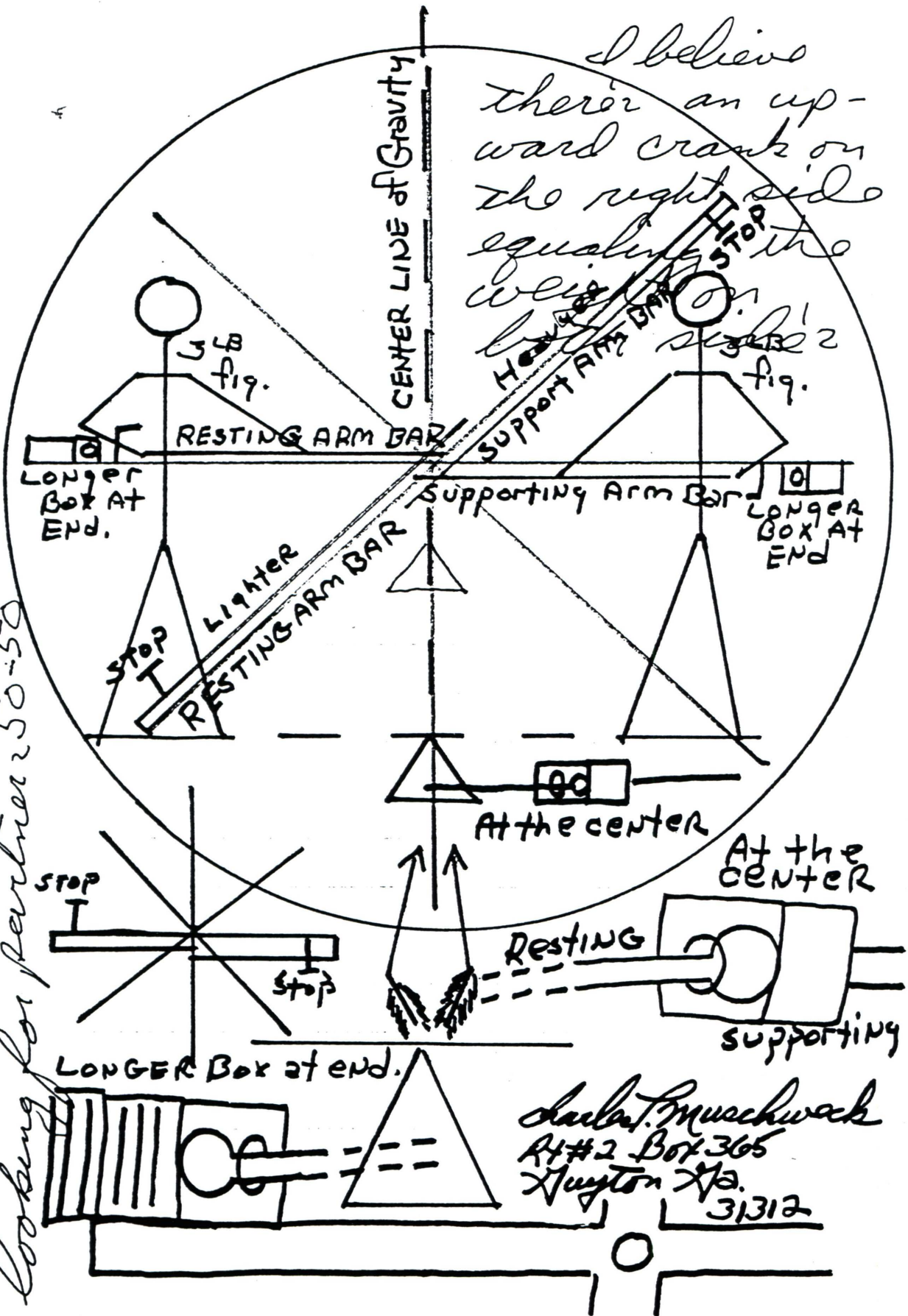



MAGNETIC WAVES put off by fast moving, low flying UFOs are burning out dozens of TV sets every week, according to electronic experts.

Experts have drawn a correlation between the baffling epidemic of burned-out TVs all over the world, especially Eastern Europe and the growing number of UFO sightings in various regions.

British scientists have measured an increase in magnetic waves just before the appearance of UFOs, and a peak in the waves as the sets burn

Magnetic UFO rays destroying dozens of TVs every week

out. "The evidence is conclusive," says Dr. Stanislaus Fedorski at Britain University's Electronics Institute.

Fedorski and other experts believe the magnet-

ic waves may be thrown off by the UFOs unique propulsion system, and may not be a conscious effort by aliens to disrupt TV viewing.

"If aliens intended to

destroy television sets, I would think them capable of destroying them all at once and in specific areas, instead of haphazardly," Fedorski says.

TV sets started to mysteriously burn out early this January in Poland, Czechoslovakia, Romania and Bulgaria as well as England.

Electronics

Without warning, screens suddenly flare up in a burst of blinding light that lasts from 10 to 15 seconds, then they go completely black.

"We thought it would be a bonanza for us at first," says Peter Tkacz, head of the TV repair guild in Prague.

"But we found that almost all the electronic parts in the sets had fused. It would have cost more to fix them than to



● TV SETS destroyed by UFOs in England are being stored for further study by researchers

buy new sets." At first, inferior workmanship was blamed because the majority of the sets in these countries are imported from mainland China.

But later reports that Japanese, German and American sets were experiencing the same problems let the Chinese off the hook.

The Polish and Czech governments say they are considering a UFO watch.

Utilizing detection instruments similar to what Fedorski used to first track the magnetic emanations, TVs can warn viewers as soon as there is a rise in the emanations, says Polish government spokesman Jakov Boroski.

"The sets can then be turned off until the emanations drop to a safe level," Boroski says.

— LOUIS MARTIN

Advertisement

SIMPKINS — By Hoyle

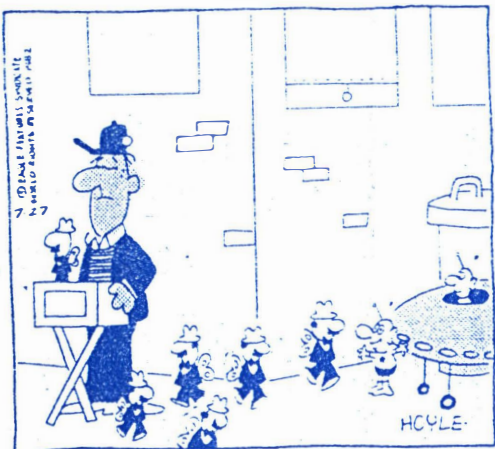

"GREETINGS EARTHLINGS!!"

T
H
A
T
S

J
A
K
E



"I'm sure this is a dandy day for the universe and all, but I don't think it bodes too well for us pig farmers."

The Far Side by Gary Larson

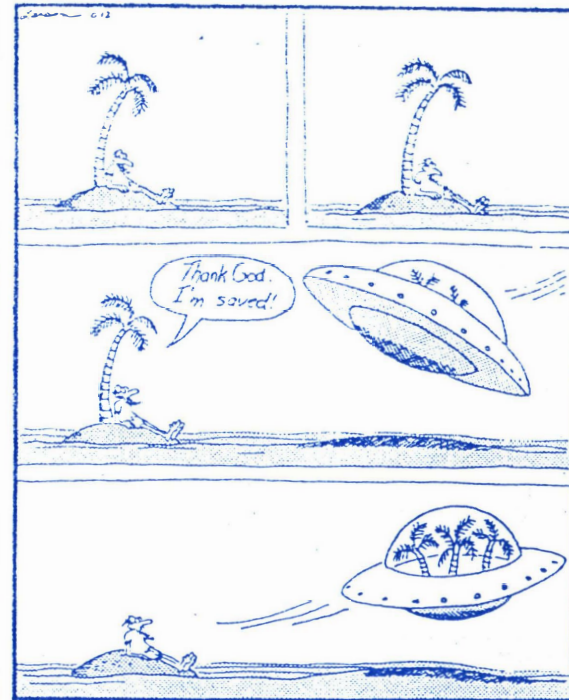

Belvedere

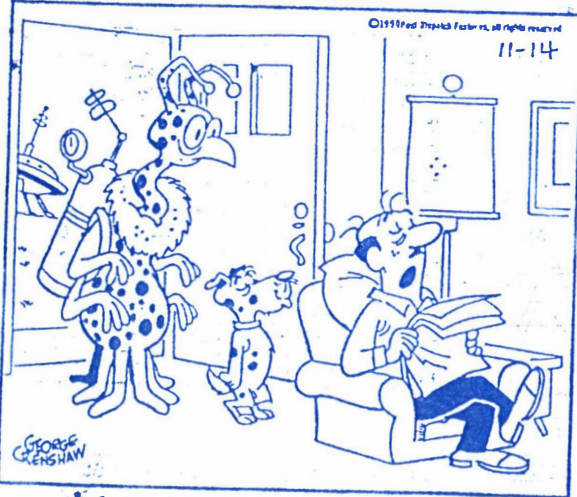

"THAT'S RIGHT. I SAID YOU COULD HAVE A FRIEND SLEEP OVERNIGHT."

VENUS FLYTRAP

Herman

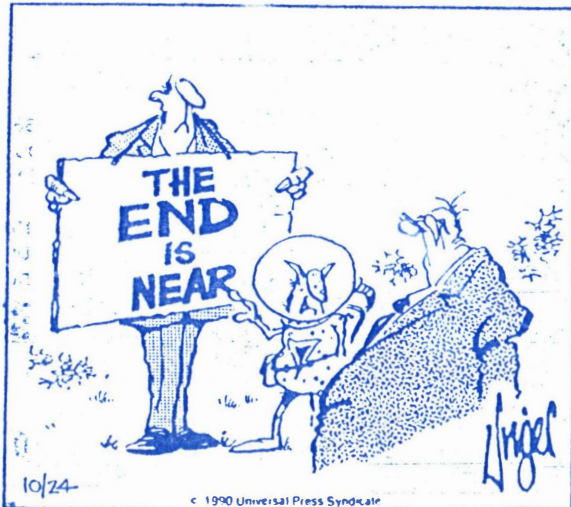

"My money's on him."

T
H
E
N
E
W
B
R
E
E
D

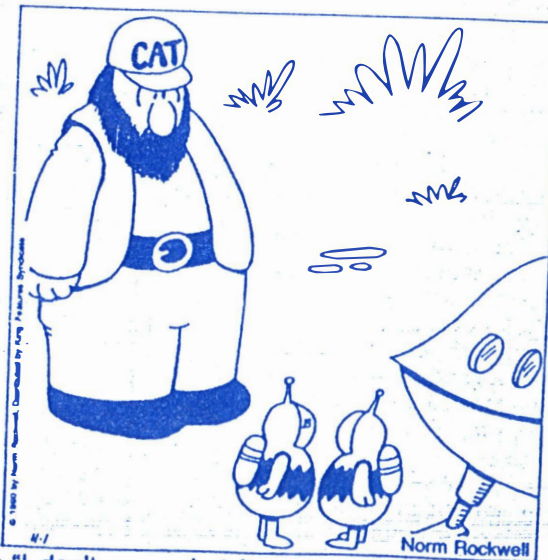

"I don't care what it says on his hat! I've seen pictures of them and he isn't one."

The following article appeared in "Strange" magazine, Number 9. copyright Strange Magazine, P.O. Box 2246, Rockville, Maryland, 20847. Anyone travelling north of Chicago, well worth visiting.

16A — Buyer's Guide, MON., MAR. 23, 1992

Lifewire

Eat junk food to thwart aliens

Copley News Service

OTHER WORLDS

If you worry about being abducted by aliens, start smoking and eat more Snickers, because ETs are repulsed by chocolate

lovers and smokers.

A group called Cosmic Awareness Communications claims to know this from information channeled through folks who say they've been abducted.

Spokesman John Strongbow

says aliens are abducting humans to kill and extract a hormone called "adrenal-chrom," which gives aliens a druglike high.

Strongbow says chocolate, cigarettes, garlic and booze give the adrenal-chrom a repugnant odor and ruin the high for the outer-space creatures.

He says the aliens are an unemotional race in danger of extinction because they can only reproduce by cloning.



Shocked North Korean air force pilots reported seeing a whole flock of flying pigs during military maneuvers over the Yellow Sea, says a report in an English language Chinese newspaper.

WEEKLY WORLD NEWS
May 14, 1991

BROOM HILDA



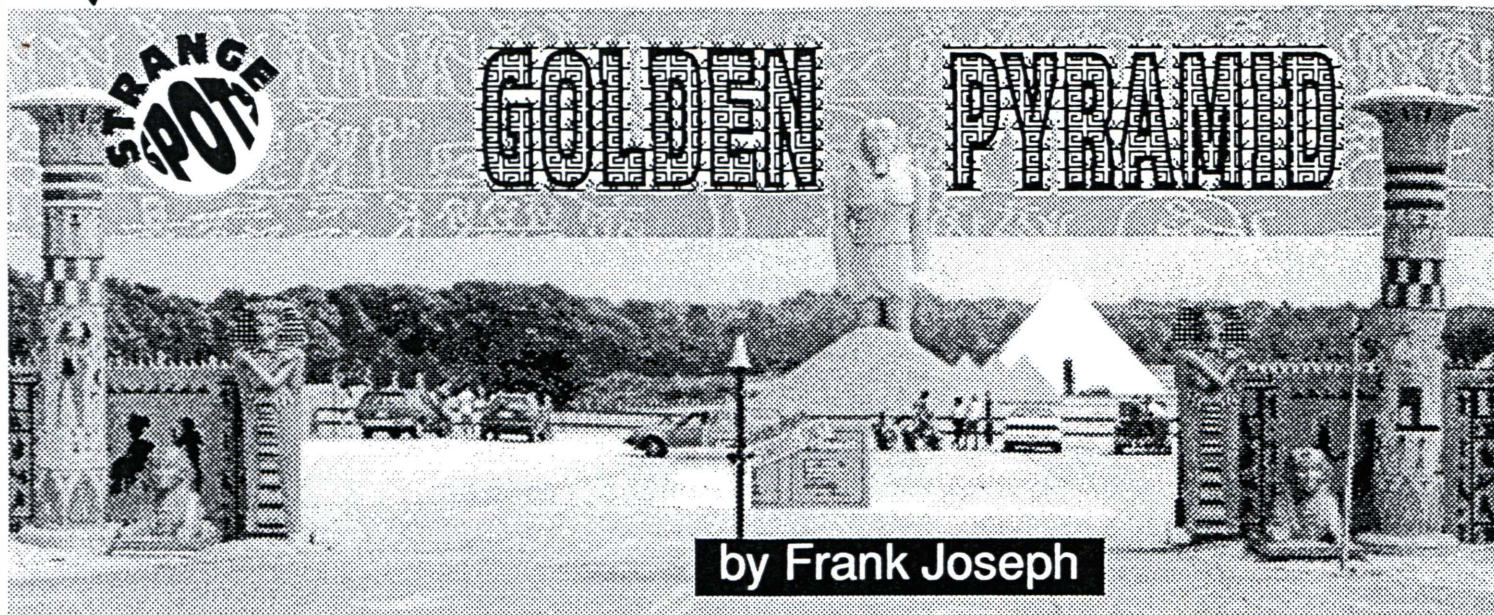

To people who imagine the Pyramid Age ended four thousand years ago in Pharaonic Egypt, the modern pyramid of northern Illinois should come as a shock. Unquestionably the most unusual structure in the Midwest, the Golden Pyramid is the creation of James Onan, a local building contractor with a life-long dream. His pyramid stands at the eastern end of a rectangular estate entered from Diley Road, in Wadsworth, a small town of prairies and woods forty miles north of Chicago.

Visitors arrive between two high Egyptian-style pillars flanked on either side by a pair of sphinxes and twin upright sarcophagi. A seven-foot-high wall decorated with hieroglyphic characters completely encloses the whole twenty-one acre complex. At the center of the complex towers the forty-foot-tall colossus of a pharaoh manufactured by the Walt Disney Studios in Hollywood, California. From this statue a paved processional walk-way proceeds for some four hundred feet between sixty full-size sphinxes arranged in two rows. The sphinx-lined walkway leads to the Golden Pyramid, which is situated on an island in the middle of a lagoon. An illuminated bridge crosses over the deceptively calm waters (stocked with live sharks!) to the island. Nearby there is a low, grey pyramid with a triple apex

used as a garage and storage room.

The main pyramid is thirty feet high and thirty feet across at its base. Its entire exterior is sheeted with a coating of real gold. In bright sunshine the structure is a dazzling apparition, even at some distance. Up close, it has an almost overpowering effect.

This untypical structure is actually the private home of the Onan family. The spacious interior contains sleeping quarters, a living room, a kitchen and a bath, like any other house, although decorated throughout in Egyptian motifs, including costly reproductions.

Leaving the island over the same bridge, the visitor returns through the boulevard of sphinxes back to the Disney titan. To the left is a recreation of King Tutankhamun's tomb containing a superb reproduction of the Pharaoh's sarcophagus and shrine—all in real gold and exquisitely crafted to order. The burial chamber contains numerous other treasures—including statues, furniture, colorful wall paintings representing Tutankhamun's "rites of rebirth," and royal grave goods—all faithfully reproduced in meticulous detail.

Behind the king's new tomb stands the gift shop supervised by Mr. Onan's wife, Linda, and her assistant, Marge May, whose knowledge of pharaonic antiquities is surpassed only by her passion for all things Egyptian. During tours of the Pyr-

amid House, she appears resplendent in the shimmering golden gown and jewels of the legendary Nefertiri.

As though this supremely unusual place were not weird enough in itself, there are aspects of it that are even stranger than its builder suspected. For example, after the foundations of the Golden Pyramid House were laid about fifteen years ago and work was proceeding rapidly, a natural spring suddenly and quite unexpectedly began gushing up at the very center of the structure. As an experienced and highly successful builder, James Onan knew where to avoid subterranean streams. Yet, against all logic, the waters appeared where none were anticipated—literally out of nowhere. But they did not interfere with construction, and the house was built around the spring, where it bubbles today, at the very center of the Golden Pyramid. Water from the spring is sold in little plastic bottles at the gift shop and some claim that it has curative and clairvoyant qualities. Natural springs, of course, were often associated with holy places, "sacred centers," in the Ancient World, particularly in Egypt, where the Osireion was an underground temple surrounded by a pool of water. It was in this hypogeum, or subterranean shrine, where the Mysteries of Osiris, the man-god of rebirth, were celebrated. His Mysteries were said to bestow the secrets of eternal life and grant deep spiritual wisdom to mortals.

Legend, too, recounts that Khufu's Great

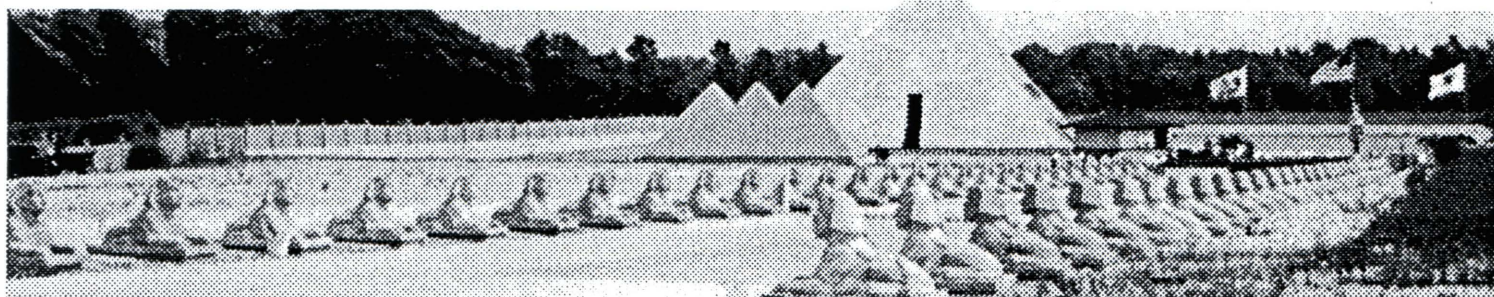

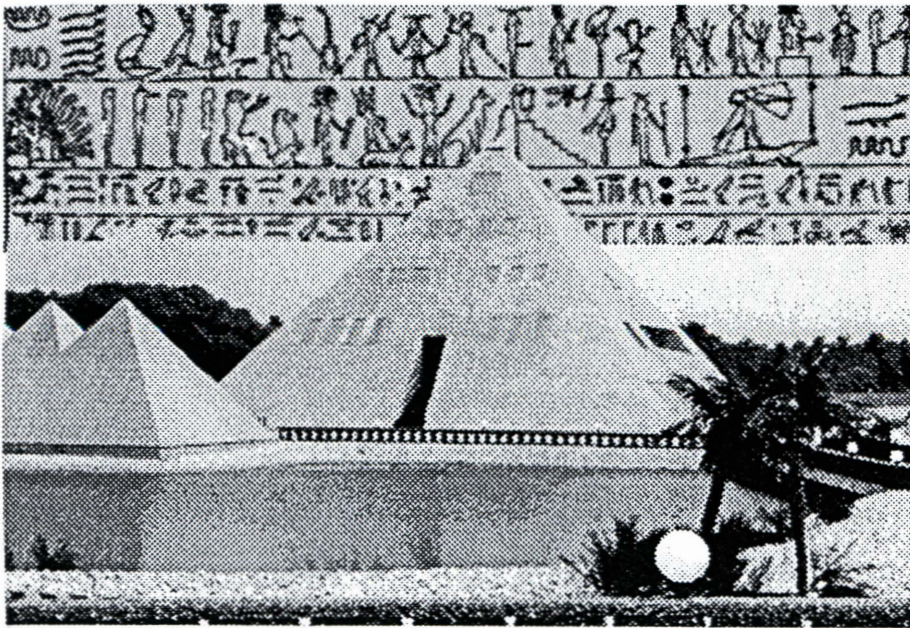

Pyramid of Giza was originally built over a sacred spring. Even the lagoon surrounding the Illinois Pyramid has its inexplicable occurrences. Before Mr. Onan stocked it with sharks, he let loose several manta rays, the so-called "Devil Fish." But originally the lagoon was uninhabited by any living creatures. Then, in the summer of 1987, large jellyfish suddenly appeared in its waters, literally overnight. They filled the lagoon with their numbers well into autumn and returned the following year, but failed to put in an appearance this summer. Over the two years of their occupation of the lagoon they were seen by many hundreds of people, and several specimens were retrieved for study and identification. Amazingly, the Golden Pyramid jellyfish were not the *Craspedacusta sowerbyi* common in the fresh waters of the Northern Hemisphere, but an outsized species of *Lucernaria*, inhabitants of the salt waters of the North Atlantic Ocean!

Lucernaria are rarely if ever found so far inland, and their chances of survival are limited to only a very few short days, at most. Yet, the Golden Pyramid jelly-

fish endured for two consecutive summers. Marine biologists at Chicago's famous Shedd Aquarium were at first incredulous, then astounded by the discovery. Regaining their scholarly composure, they dismissed the Pyramid jelly fish as the result of bird-droppings, refusing to admit any marine phenomena existed beyond their understanding.

Unknown to James Onan at the time he undertook construction, another ancient, authentic pyramid lay in a field just south of Route 132, not five miles southwest of his Golden Pyramid. The twenty-foot-high structure is an earthen burial mound, the only one of its kind in northern Illinois, perhaps dating back to the Early Mississippian Period, a little more than a thousand years ago.

The Golden Pyramid is an amazing attraction and is well worth a visit for anyone interested in strange spots.

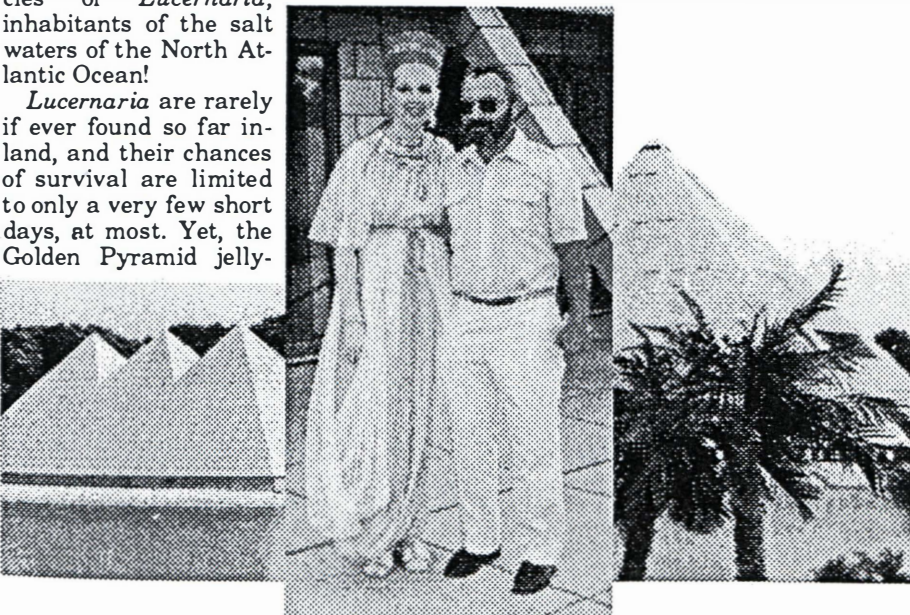

GODDESS SITES: EUROPE

by Anneli S. Rufus and Kristan Lawson
HarperCollins Publishers, New York,
1990, 319 pp., bibl., illus., index, paper,
\$12.95

Reviewed by Douglas Chapman

Rufus and Lawson are responsible for truly amazing travel guides. Having authored *Europe Off the Wall* and *America Off the Wall*, they have now followed up with *Goddess Sites: Europe*, a tome which will delight those who wish to, as the subtitle puts it, *Discover Places Where the Goddess Has Been Celebrated and Worshipped Throughout Time*.

Organized by country, each entry describes a sacred site and its religious history, gives directions and particulars of admission, and tells of the continued thrall of each Goddess—despite opposition.

Whether one seeks Isis, Venus, Diana, Maeve, Cybele, Hera, Athena, Minerva or the Virgin Mary, this travel guide will help one locate the European or Mediterranean sites where she may be found. Many shrines to the latter are mere Christian adaptations of the Goddesses who previously held sway. The authors describe the process, when writing about Chartres in France: "Don't you realize, they [the Christian evangelizers] cried out to the stubborn Gauls, that the statue you worship represents the Virgin Mary? You're Christians already and you don't even know it! Why, we'll build a new church on your holy shrine, put your statue in the church, and, heck we'll even worship it ourselves!" And thus statues from before Mary's time became "prefigurations of the Virgin."

The book covers the major Goddess sites, such as Athena's Acropolis in Greece, as well as the lesser-known ones, like the mound called Queen Maeve's Place in Rathcroghan, Ireland. Some of them date to antiquity.

Czechoslovakia was an early home to the Goddess. At Dolni Vestonice, a baked-clay Stone Age goddess was found by archeologists. As is typical of the period, it is depicted as very pregnant. Its replica remains at the museum there, but the original was removed to Prague. If one wants to see the Dolni Vestonice archeological dig, one can use the nearest city—Vienna, Austria—as a jumping off point.

In Chester, England, one can meet one's Nemesis. The Romans who invaded Britain certainly did; there is a shrine to the goddess Nemesis inside an ancient military amphitheater where the bloodiest of games were once played. And now, even though an Ursuline convent covers the still-buried half of the place, the shrine—in reconstructed glory—commands attention.

The churches of England often have unusual, rather pagan, decorations, of which the stone carvings of the sheela-na-gigs are probably the strangest. Even though later ones were carved in a Christian context, they are still blatantly sexual, representing a woman holding open enormous genitals. Examples can be found in Church Stretton, Holdgate, Kilpeck, Oxford and Tugford.

Other fascinating entries describe the Black Madonnas of France; the bear Goddess of Berne, Switzerland; and the Sanctuary of Artemis of the Bears in Vravrona, Greece. Mythology and religion will be enlivened for those who follow the authors' leads.

The book is best if taken in small doses, because of stylistic repetition, but will prove useful for those seeking out the human religious legacy.

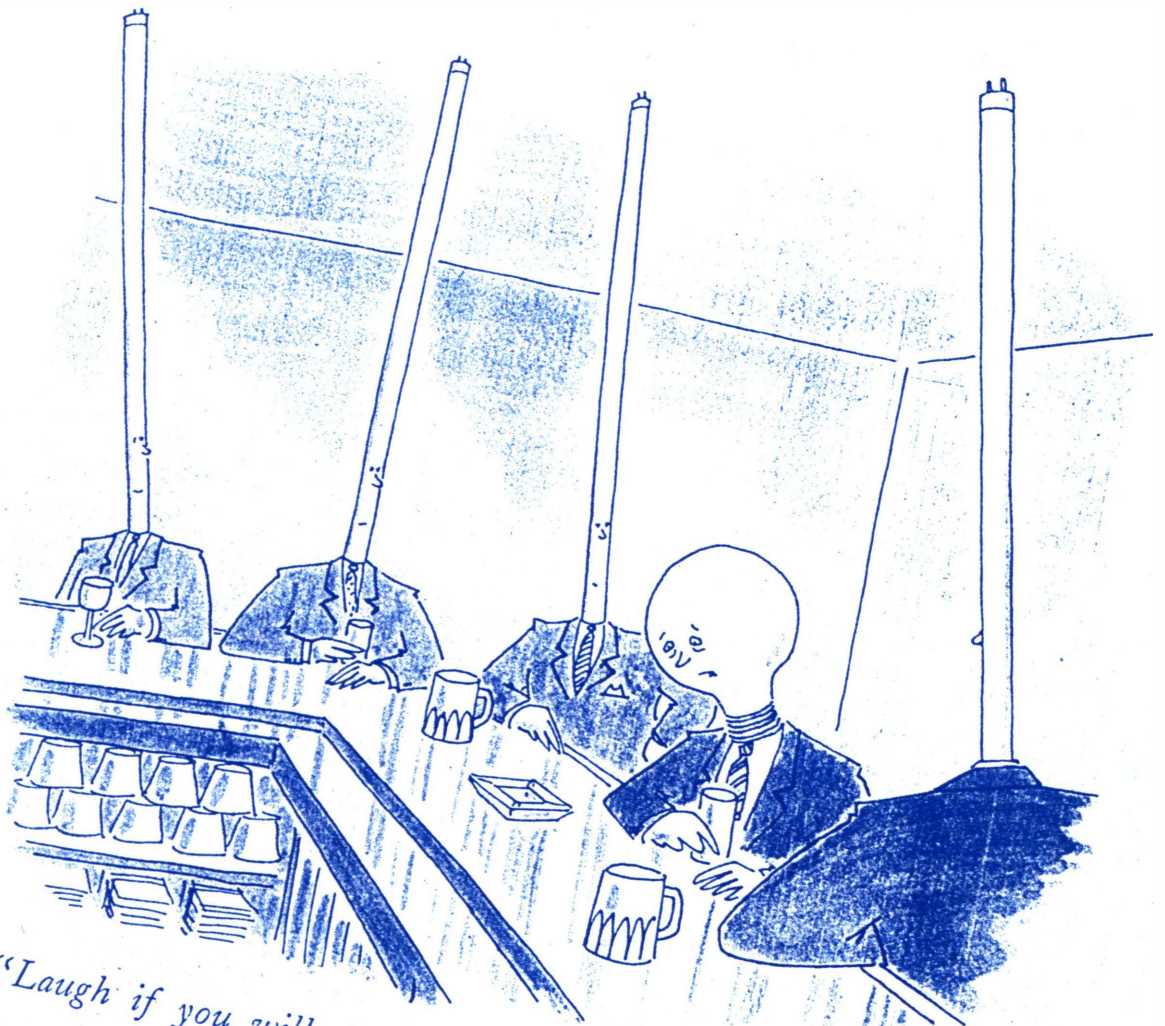

"Laugh if you will, but my kind once ruled the earth."

ZEGGER